

HITACHI

Inspire the Next

Quick Installation Guide Hitachi Travelstar C4K60 Slim

Models: HTC426060G8CE00
HTC426040G8CE00
HTC426030G5CE00
HTC426020G5CE00



Handling precautions

- Set the drive down gently to prevent damage from impact or vibration.
- Handle the drive carefully by the edges. Do not touch the exposed printed circuit board or any electronic components.
- Do not press on the top or bottom of the drive.
- Before handling the drive, discharge any static electricity from yourself and your clothing. With one hand touch an unpainted metal surface, then touch the ESD bag with the other hand. Remain in contact with the chassis and the bag for a minimum of two seconds.
- Vibration, shock and static electricity to the drive will damage the precision parts. In particular, prevent vibration or shock generated by dropping, knocking over or hitting the drive. Also, avoid touching the electrical components directly, which can discharge electrostatic energy and damage the drive.

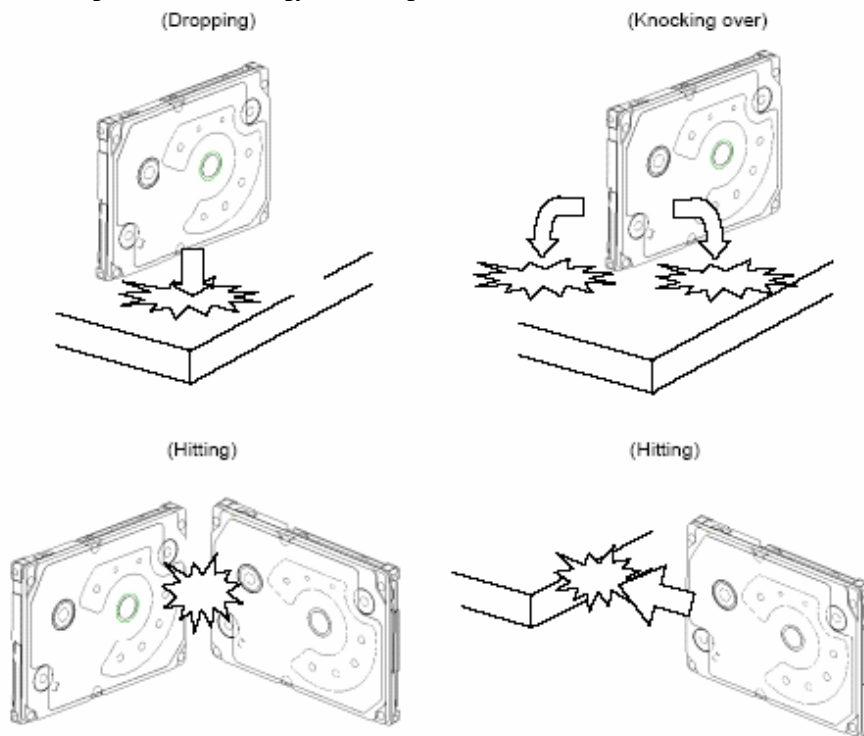

Mounting Recommendations

- There are no screw holes in the Travelstar C4K60 Slim hard disk drive. Hitachi recommends you secure the drive by placing it in a case as shown in the diagram below. Hitachi GST will assist customers with mounting design.

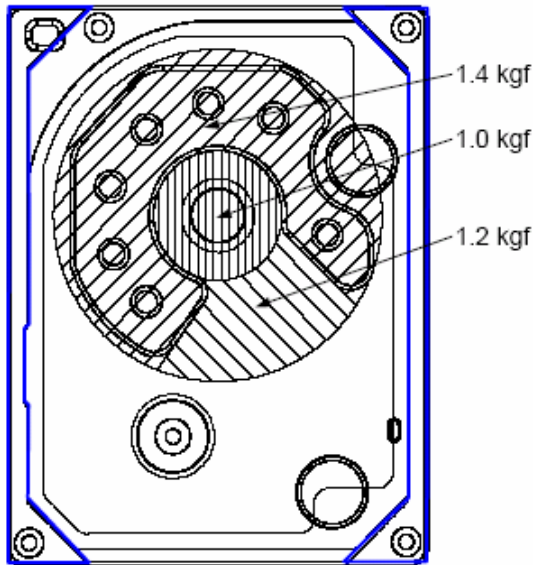

- **Do not push a striped area.**
To avoid mechanical contact between HDD cover and the movable part in HDD, striped area should not be pushed. The number shows boundary value to start contact.
- **To secure air flow, Do not make airtight on HDD surface as much as possible.**
- **The PCBA side of the drive should be covered with isolation sheet if the active metal of host system may contact to the PCBA of the drive.**
- **Give FPC enough length to avoid excessive tension under shock condition.**

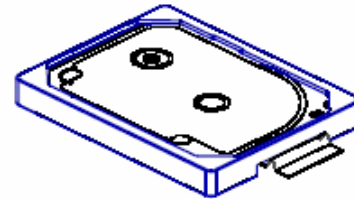

- **Recommended Material:**
"E-A-R's ISODAMP" is suggested to use.
Need to select appropriate material ingredient (outgas) for HDD. Outgas of Silicone rubber gives serious damage to HDD etc.

- The temperature of the center of the hard drive cover should remain less than 65°C at all times.
- The inertia of the chassis around the Z-axis of the gravity center of the device must be more than $3 \times 10^{-4} \text{kg m}^2$.
- In case of general Sub-notebook PC weight (1.7kg), the inertia of the chassis around the Z-axis of the gravity center of the device is greater than $100 \times 10^{-4} \text{kg m}^2$. Therefore, the required inertia level does not conflict with the general electronic equipment.
- If installing the C4K60 next to a steel plate, the cover of the C4K60 and the steel plate must have at least 2mm of space between them. This is necessary for air flow and cooling requirements.
- The PCBA side of the drive should be covered with insulation if it is in contact with any metal part of the host system. Contact between the PCBA and metal may result in drive failure.
- The blue frame shown below represents the casing used when the drive can not be secured with screws.

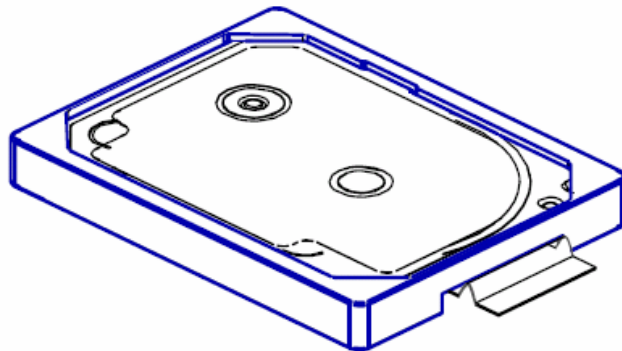

Dimensions and Mounting area

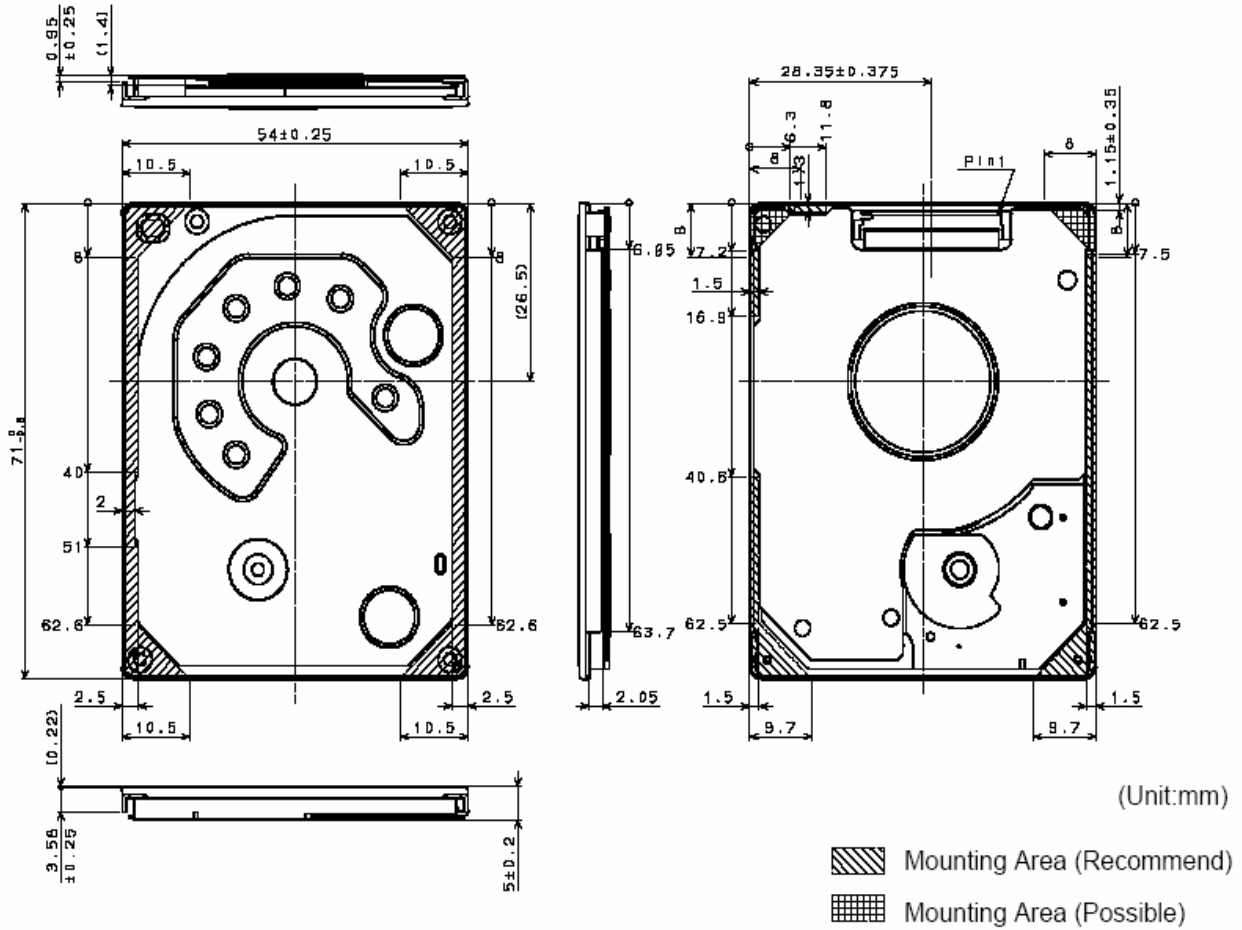

Recommended drop shock material distributors

<http://www.earsc.com/>

© Copyright Hitachi Global Storage Technologies

Hitachi Global Storage Technologies
5600 Cottle Road
San Jose, CA 95193

Produced in the United States

9/05

All rights reserved Travelstar™ is a trademark of Hitachi Global Storage Technologies.

Microsoft, Windows XP, and Windows are trademarks of Microsoft Corporation in the United States, other countries, or both.

Other product names are trademarks or registered trademarks of their respective companies.

References in this publication to Hitachi Global Storage Technologies products, programs or services do not imply that Hitachi Global Storage Technologies intends to make these available in all countries in which Hitachi Global Storage Technologies operates.

Product information is provided for information purposes only and does not constitute a warranty.

Information is true as of the date of publication and is subject to change. Actual results may vary.

This publication is for general guidance only. Photographs may show design models.

02 September 2005
