

IBM OEM STORAGE PRODUCTS

Travelstar XP

DPRA-20810 and DPRA-21215

The latest 2.5" disk drives from IBM provide up to 1215MB in a slim 17mm high package. Using the latest MR head technology and IBM's patented No-ID(TM) sector formatting, IBM provides high performance, high capacity drives, particularly suited to the mobile computing market, and its increasing application of multimedia.

Applications

- High performance portable computers
- Non-IT - process control/fax
- Removable/secure storage units

Features

- 810/1215MB at (512 bytes/sector).
- Enhanced IDE interface with DMA data transfer
- - Single word: mode 2 (8.3MB/sec).
- - Multi word: mode 1 (11.1MB/sec).
- PIO data transfer - mode 3 (11.1MB/sec)
- Shock 300G (2ms) non-operational.
- Shock 100G (2ms) operational.
- Media data rate 36.3/57.0 Mbits/s (8 zones).
- Rotational speed 4900 rpm.
- Average seek 12 milliseconds (Read)
- Magneto resistive heads.
- No-ID(TM) sector formatting.
- 64KB segmented buffer.
- Enhanced ECC on the fly.
- Power saving modes.
- Spin up 3.0 sec (typical).
- MTBF 300,000 hours.

Benefits

- Highest capacity in 2.5" form factor
- Popular interface with excellent performance
- Robust design for portable computing applications
- Excellent data rate across disk surface
- High areal density, low component count
- More data stored per track, increased sustained data transfer rate

- Fast access to data and improved throughput
- Low power for battery powered applications
- Fast recovery from standby
- Assured reliability

Electrical Connector Locations

Drive Address

A jumper cable is available at the interface connector to determine the drive address. Using Cable Selection, the drive address depends on the condition of pin 28 of the AT interface cable. In the case when pin 28 is ground or low, the drive is a Master. If pin 28 is open or high level, the drive is a Slave.

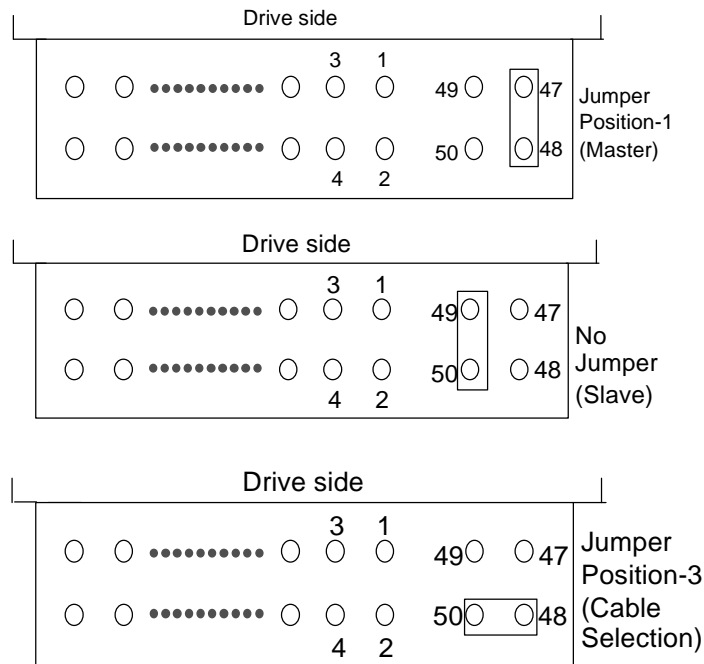

Cabling

The maximum cable length from the host system to the HDD plus circuit pattern in the host system shall not exceed 18 inches.

AT Signal Connector

The AT signal connector is designed to mate with Dupont part number 69764-044 or equivalent.

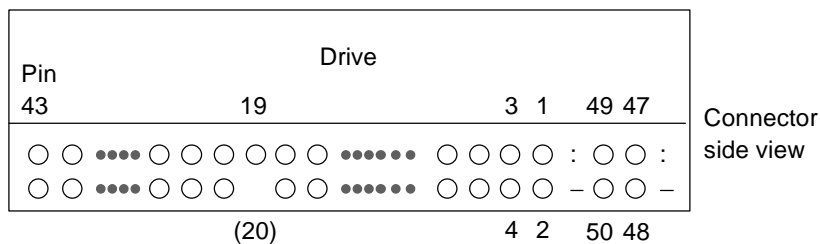

Notes:

1. Pin position 20 is left blank for secure connector insertion.
2. Pin position 47 through 50 are used for drive address setting.

Data Organization

<i>DPRA</i>	-20810	-21215
Head Number	16	16
Sectors/Track	63	63
Cylinder Number	1572	2358
Sector Size	512	512
Total Customer		
Usable Data Sectors	1,584,576	2,376,864
Total Customer		
Usable Data Bytes	810MB	1215MB

DC Power Requirements

Supply Voltage	+5 Volts
Power Supply Ripple (0-20 Mhz) 1	100mv p-p max
Tolerance 2	+/-5%
Supply Current	Pop. Mean
Idle average 3	0.26A RMS (1.3W)
Read/Write	0.52A RMS (2.6W)
Seek average 4	0.52A RMS (2.6W)
Standby	0.06A RMS (0.3W)
Sleep	0.02A RMS (0.1W)
Start Up	
(maximum peak) 5	0.94A RMS (4.7W)
(average from power on to ready)	0.70A RMS (3.5W)
Supply Rise Time	7-100 ms

Notes:

1. The maximum supply ripple is measured at 5V input of the HDD.
2. The disk drive shall not incur damage for an over voltage condition of +25% (maximum duration of 20ms) on the 5 volt nominal supply.
3. Idle current is specified at inner track.
4. The seek average current is specified based on three operations per 100.
5. The worst case operating current includes motor surge.

Signal Definition

The pin assignments of interface signals are listed as follows:

PIN	Signal	I/O	PIN	Signal	I/O
-----	--------	-----	-----	--------	-----

01	-HRESET	I	02	GND	
03	HD07	I/O	04	HD08	I/O
05	HD06	I/O	06	HD09	I/O
07	HD05	I/O	08	HD10	I/O
09	HD04	I/O	10	HD11	I/O
11	HD03	I/O	12	HD12	I/O
13	HD02	I/O	14	HD13	I/O
15	HD01	I/O	16	HD14	I/O
17	HD00	I/O	18	HD15	I/O
19	GND		(20)	Key	
21	DMARQ	O	22	GND	
23	-HIOW	I	24	GND	
25	-HIOR	I	26	GND	
27	HIORDY	O	28	CSEL	
29	-DMACK	I	30	GND	
31	HIRQ	O	32	-HIOCS16	O
33	HA01	I	34	-PDIAG	I/O
35	HA00	I	36	HA02	I
37	-HCSO	I	38	-HCS1	I
39	-DASP	I/O	40	GND	
41	+5V Logic	PWR	42	+5V Motor	PWR
43	GND		44	(Resv)	

Note:

"O" designates an output from the drive.

"I" designates an input to the drive.

"I/O" designates an input/output common.

"PWR" designates a power supply to the drive.

"(Resv)" designates reserved pins which must be left unconnected.

Note:

There are two input pins for +5 Volt power supply, "+5V LOGIC" and "+5V MOTOR". "+5V LOGIC" is connected to the internal logic circuits and "+5V MOTOR" is connected to the spindle motor and motor driver.

It is possible to turn on and off "+5V LOGIC" by an external switch circuit to reduce power consumption to the least possible. In this mode, a voltage drop out due to the motor spin up current can be reduced by connecting "+5V MOTOR" line into the system power source directly. If the above power management option is used, all signal lines that will be electrically active in the host system while the HDD is disconnected from power line, shall be isolated by Three-State line drivers. Internal leakage through ESD protection circuit may pull down LPUL (Least Positive Up Level) of logic signal below specification.

Use both lines in parallel, for regular HDD applications.

Command Description

The following Commands are supported by the Drive:

Commands	(HEX)
Check Power Mode	(E5)
Check Power Mode*	(98)
Disable Password	(F6)
Execute File Diagnostics	(90)
Erase Prepare	(F3)
Erase Unit	(F4)
Format Track	(50)
Freeze Lock	(F5)
Identify File	(EC)
Idle	(E3)
Idle*	(97)
Idle Immediate	(E1)
Idle Immediate*	(95)
Initialize File Parameters	(91)
Read Buffer	(E4)
Read DMA (retry)	(C8)
Read DMA (no retry)	(C9)
Read Long (retry)	(22)
Read Long (no retry)	(23)
Read Multiple	(C4)
Read Sectors (retry)	(20)
Read Sectors (no retry)	(21)
Read Verify Sectors (retry)	(40)
Read Verify Sectors (no retry)	(41)
Recalibrate	(1X)
Seek	(7X)
Set Features	(EF)
Set Multiple	(C6)
Set Password	(F1)
Sleep	(E6)
Sleep*	(99)
Standby	(E2)
Standby*	(96)
Standby Immediate	(EO)
Standby Immediate*	(94)
Unlock	(F2)
Write Buffer	(E8)
Write DMA (retry)	(CA)
Write DMA (no retry)	(CB)
Write Long (retry)	(32)
Write Long (no retry)	(33)
Write Multiple	(C5)
Write Sectors (retry)	(30)

Write Sectors (no retry) (31)
Write Verify (3C)
* Alternate Command codes.

Operating Modes

Description

Spin-Up

Start up time period from spindle stop or power down.

Seek

Seek operation mode.

Write

Write operation mode.

Read

Read operation mode.

Idle

Spindle motor and Servo system are working normally. Other modules except the servo control and Host Interface are sleeping. Commands can be received and processed immediately.

Standby

Spindle motor is stopped. All modules except Interface are sleeping. Commands can be received immediately. HDD is in an interrupt waiting mode with the lowest power dissipation.

Notes:

1. Upon power down or Spindle stopped, a head locking mechanism will secure the heads in the ID parking position.
2. Sleep command is handled like the Standby command. Recovering from standby mode does not need soft reset nor hard reset.

Electromagnetic Compatibility

The drive meets the following EMC requirements when installed in a host system and exercised with a random accessing routine at maximum data rate:

United States Federal Communication Commission (FCC) Rules and Regulations Part 15, Subject J - Computer Devices "Class B Limits".

European Economic Community (EEC) directive #76/889 related to the control of radio frequency interference and the Verband Deutscher Elektrotechniker (VDE) requirements of Germany (GOP).

Operating Environment

Humidity:

Operating	8% to 90%
Relative	non-condensing
Non-Operating	5% to 95%
Relative	non-condensing

Wet Bulb Temperature:

Maximum Wet Bulb:

Operating	29.4 degrees C non-condensing
Non-Operating	40 degrees C non-condensing

Elevation:

Operating Altitude	-300 to 3000m
Ship/Storage Altitude	-300 to 12000m

Temperature:

Operating	5 degrees to 55 degrees C*
Storage	0 degrees to 65 degrees C
Shipping	-40 degrees to 65 degrees C
Temperature Gradient (Operating, storage & shipping)	20 degrees C per hour (maximum)

** Note:*

The system is responsible for providing sufficient air movement to maintain surface temperature below 60 deg C at the center of top cover of file.

Air Cooling Requirement

The host system must provide sufficient air flow across the drive to maintain the temperature at less than 60 degrees C (measured at the center of the file's top cover).

Operating Shock

The Drive will withstand (with no hard error) a 100G half-sine wave shock pulse of 2ms duration

Non-Operating Shock

The Drive will withstand (with no permanent damage or degradation in performance) a 120G half-sine wave shock pulse of 11ms duration or 300G for 2ms.

Operating and Non-Operating Vibration

Due to the complexity of this subject we recommend that users contact the Distributor to discuss how to perform the necessary measurements if they believe this to be an area which requires evaluation.

Caution

DO NOT PRESS on the DRIVE!

- Do not press when you take out the drive.
- Do not press when you carry the drive.
- Attach the drive free from pressing force.

Mechanical Data

Dimensions

DPRA-20810/21215

Height(mm)	17.0
Width(mm)	69.85
Length(mm)	100.2
Weight(gram)	186 max

Mounting Orientation

The drive will operate in all axes (6 directions). The drive will operate within the specified error rates when tilted +/-5 degrees from these positions.

Performance and error rate will stay within specification limits if the drive is operated in the other permissible orientations from which it was formatted. Thus a drive formatted in a horizontal orientation will be able to run vertically and vice versa.

The drive must be securely mounted in the system to prevent motion or vibration during a seek operation or spindle rotation using appropriate screws or equivalent mounting hardware.

Vibration and shock tests are to be conducted with the drive mounted to the equipment using the bottom four screw holes.

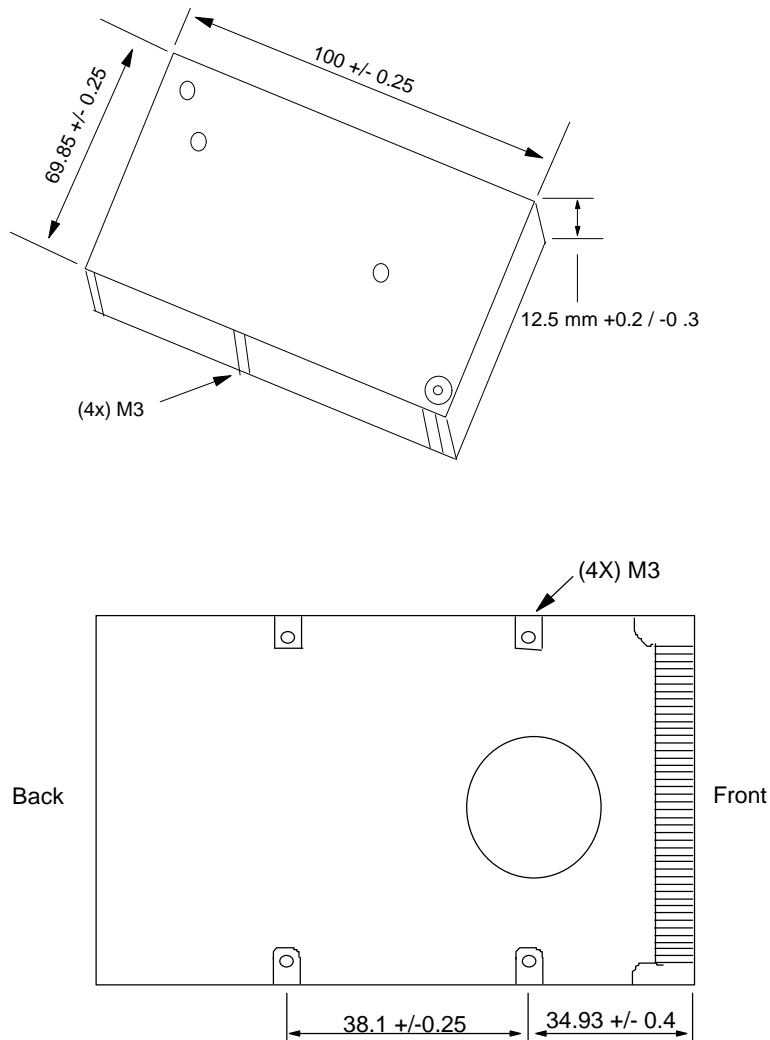

The recommended mounting screw torque is 3 +/-0.5 kgf.cm.

The recommended mounting screw depth is 3.5 +/-0.5mm for bottom and 5.0 +/-0.5mm for horizontal mounting.

WARNING:This disk drive can be damaged by Electro-Static Discharge; please follow recommended ESD procedures before unpacking or handling the drive. Ask your Dealer for details if you need assistance.

PACKAGING: The drive must be protected against Electro-Static Discharge especially when being handled. The safest way to avoid damage is to put the drive in an anti-static bag before ESD wrist straps etc, are removed.

Drives should only be shipped in approved containers; severe damage can be caused to the drive if the packaging does not adequately protect against the shock levels induced when a box is dropped. Consult your IBM marketing representative if you do not have an approved shipping container.

AMP is a trademark of AMP Incorporated.

Molex is a trademark of Molex Incorporated.

DATA MATE is a trademark of AMP Incorporated.

Western Digital is a trademark of the Western Digital Corporation.

NEXT is a trademark of NEXT Corporation.

This data sheet is not a substitute for the full product specification, which should be used when detailed information is required.

Product Description data represents IBM's design objectives and is provided for comparative purposes; actual results may vary based on a variety of factors. This product data does not constitute a warranty. Questions regarding IBM's warranty terms or methodology used to derive this data should be referred to your IBM OEM representative. Data subject to change without notice.