

HITACHI

Inspire the Next

Product summary

Hitachi 3K4 Microdrive

CF+ Type II

Models: HMS360404D5CF00
HMS360402D5CF00



Introduction

The Hitachi 3K4 Microdrive comes in capacities of 4 GB and 2 GB. Developed to meet the needs of handheld systems and devices, it is one of the highest capacity hard disk drives available in a one-inch diameter.

Applications

- Digital photography cameras
- Handheld PCs
- Personal Data Attendants
- Digital video cameras

Features

- Formatted capacities: 4 GB, 2 GB at 512 bytes per sector
- CF+ Type II Card compliance
- Shock: 2000 G (1 ms) non-operational
- Shock: 200 G (2 ms) operational
- 57.1 – 97.9 Mb/s media data transfer rate
- Rotational speed: 3600 RPM
- Average seek time: 12 ms (read)
- Average latency: 8.3 ms
- Areal density: 56.5 Gbits/square inch
- No-ID sector formatting
- PRML data channel
- 128 KB buffer for read and write
- On The Fly correction
- Load/Unload heads
- Giant Magnetoresistive heads
- Adaptive power save control

Benefits

- High capacity in a compact 1-inch diameter form factor
- Popular interface with a wide array of applications
- Robust design for portable computing applications
- Excellent data rate across disk surface
- Fast access to data
- Increased storage capacity
- More data stored per track, increased sustained data transfer rate
- Fast access to data and improved throughput
- High reliability
- Increased durability during power save modes and non-operation
- High areal density, low component count
- Low power for battery powered applications

Data organization (logical)

	HMS360404D5CF00	HMS360402D5CF00
Number of logical heads	16	16
Logical sectors/track	63	63
Number of logical cylinders	7936	3968
Logical sector size	512	512
Total customer usable data sectors	7,999,488	3,999,744
Total customer usable data bytes	4,095,737,856	2,047,868,928

DC power requirements

Power supply	+3.3 V power supply case	+5 V power supply case	Notes
Nominal supply	+3.3 volts	+5 volt	
Power supply ripple (0 – 20Mhz)	70 mV p-p max	100 mV p-p max	1
Tolerance	±5%		2
Supply current	Population mean (nominal condition)		
Performance Idle average	225 mA	230 mA	3
Low power idle average	67 mA	72 mA	
Read	303 mA	315 mA	4
Write	305 mA	314 mA	
Seek average	265 mA	230 mA	5
Standby	16 mA	18 mA	
Peak (maximum RMS in .5 ms windows)	363 mA	385 mA	6

Notes

1. The maximum fixed disk ripple is measured at 3.3 / 5 V input of the drive.
2. The disk drive shall not incur damage for an over-voltage condition of +25% (maximum duration of 20 ms) on the 3.3 / 5-volt nominal supply.
3. The idle current is specified at an inner track.
4. The read/write current is specified at 100% duty.
5. The seek average current is specified based on three operations per 100 ms.
6. The worst-case operating current at unloading.

Interface connector

The interface connector of the Hitachi Microdrive complies with CompactFlash Specification, Revision 1.4.



ATTENTION: The drive must be protected against electrostatic discharge (ESD) especially when being handled. The safest way to avoid damage is to put the drive in an anti-static bag before ESD wrist straps are removed.

Drives should only be shipped in approved containers. Severe damage can be caused to the drive if the packaging does not adequately protect against the shock levels induced when a box is dropped. Consult your Hitachi representative if you do not have an approved shipping container.

Command descriptions

The following commands are supported by the drive:

Class	COMMAND	Code (hex)
1	Access Metadata Storage	B8h
1	Check Power Mode	E5h or 98h
1	Execute Device Diagnostic	90h
1	Erase Sector(s)	C0h
2	Format Track	50h
1	Identify Device	ECh
1	Idle	E3h or 97h
1	Idle Immediate	E1h or 95h
1	Initialize Device Parameters	91h
1	Read Buffer	E4h
1	Read DMA	C8h or C9h
1	Read Long Sector	22h or 23h
1	Read Multiple	C4h
1	Read Sector(s)	20h or 21h
1	Read Verify Sector(s)	40h or 41h
1	Recalibrate	1Xh
1	Request Sense	03h
1	Seek	7Xh
1	Sense Condition	F0h
1	Set Features	EFh
1	Set Multiple Mode	C6h
1	Set Sleep Mode	E6h or 99h
1	Standby	E2h or 96h
1	Standby Immediate	E0h or 94h
1	Translate Sector	87h
1	Wear Level	F5h
2	Write Buffer	E8h
2	Write DMA	CAh or CBh
2	Write Long Sector	32h or 33h
3	Write Multiple	C5h
3	Write Multiple w/o erase	CDh
2	Write Sector(s)	30h or 31h
2	Write Sector(s) w/o Erase	38h
3	Write Verify	3Ch

Class commands

Class 1. Upon receipt of a Class 1 command, the card sets BSY within 400 ns.

Class 2. Upon receipt of a Class 2 command, the card sets BSY within 400 ns, sets up the sector buffer for a write operation, sets DRQ within 700 us, and clears BSY within 400 ns of setting DRQ.

Class 3. Upon receipt of a Class 3 command, the card sets BSY within 400 ns, sets up the sector buffer for a write operation, sets DRQ within 20 ms (assuming no reassignments), and clears BSY within 400 ns of setting DRQ.

Signal definition

For signal definition, refer to CompactFlash Specification, version 1.4

Load/Unload heads

When used properly, the Load/Unload mechanism is designed to allow 300,000 cycles of starts and stops. Invoking one of the following commands unloads the heads:

SOFT RESET
STANDBY
STANDBY IMMEDIATE

The Load/Unload mechanism is also invoked as one of the idle modes. After a short period of inactivity the Adaptive Battery Life Extender power management will unload the heads to conserve energy. When the heads are unloaded, they rest in a small detent. To prevent the heads from being thrown off the ramp during angular acceleration, a bi-directional, normally open, mechanical latch engages with the actuator to keep it from turning in the head loading direction. This action causes a "rattle" sound to be heard which can be mistaken for loose parts.

Adaptive Battery Life Extender-3

The Adaptive Battery Life Extender-3 (ABLE-3) provides power saving without performance degradation. ABLE-3 technology automatically determines the correct time to start removing power from the drive electronics.

Most software and operating systems make use of a disk drive in bursts. The Hitachi Microdrive monitors the commands sent from the host to detect patterns which indicate that a command sequence is finished by putting the drive into low overall power consumption and longer battery life with no loss in performance. If the host system changes the number or frequency of the commands sent, the disk drive automatically adapts to this new pattern.

This feature has three idle modes:

- Performance idle
- Active idle mode
- Low Power idle

Operating modes

To provide the greatest flexibility of operation with optimum performance and power consumption, the drive has a number of operating modes. These are defined below.

Spin Up

Start up time period from spindle stop or power down.

Seek

Seek operation mode

Write

Write operation mode

Read

Read operation mode

Performance idle

The device is capable of responding immediately to media access requests. All electronic components remain powered and full frequency servo remains operational.

Low Power idle

Spindle motor is rotating normally with actuator unloaded to the parking positions.

Standby

The device interface is capable of accepting commands. Spindle motor is stopped. All circuitry except host interface is in power saving mode. The execution of commands is delayed until spindle becomes ready.

Sleep

Same as Standby

Electromagnetic compatibility

When installed in a suitable enclosure and exercised with a random accessing routine at the maximum data rate, the drive meets the world-wide EMC requirements of the United States Federal Communications Commission (FCC) Rules and Regulations (Class B), Part 15.

This drive is certified for compliance to EC directive 89/336/EEC.

C-Tick Mark complies with Australian EMC standard, AS/NZS 3548:1995 Class B.

The drive complies with Taiwan BSMI.

Operating environment

The drive operates within its performance limits when the following environment is maintained. Product life calculations are based on the nominal environment for a typical application.

Relative humidity
(non-condensing)

Operating	8% to 90%
Non-operating	5% to 95%

Wet bulb temperature
(non-condensing maximum)

Operating	29.4°C
Non-operating	40°C

Elevation

Operating altitude	-300 - 3,000m
Non-operating altitude	-300 - 12,000m

Temperature

Operating	0 to 70°C
Non-operating	-40 to 70°C
Temp. gradient-operating (max)	5°C/hour
Temp. gradient-non-operating (max)	5°C/hour

Cooling requirement

The host system must provide sufficient airflow across the drive to maintain the temperature at less than 65°C at the center of the top cover of the drive.

Operating shock

No data loss or permanent damage occurs during a half-sine shock pulse of 1960 m/sec² of 2-ms duration and a half-sine shock pulse of 98 m/sec² of 11-ms duration.

Non-operating shock

The disk drive must withstand with no damage a half-sine wave shock pulse of 1176 m/sec² of 11-ms duration and a half-sine wave shock pulse of 19600 m/sec² of 1ms duration on six sides when heads are unloaded.

Operating and non-operating vibration

Due to the complexity of this subject we recommend that users contact the distributor to discuss how to perform the necessary measurements if they believe this to be an area which requires evaluation.

Drive usage conditions

The drive is designed to be used under the following conditions:

- Levels of shock, vibration, temperature, humidity, altitude, and magnetic field are within the specifications.
- Precautions are taken to prevent electrostatic discharge (ESD).
- The breathing hole on top of the drive is not covered.
- Pressure is not applied to the top cover of the drive.
- The drive is operated within the specification of less than 140 power-on hours per month.
- The Seeking, Writing, and Reading operations of the drive constitute no more than 20% of power-on hours.
- The power requirements of the drive are satisfied.
- The interface connector is firmly mated.
- The proper power off sequence is followed (see the drive specification for further details).

Mechanical data

Dimensions

Height	5.0 + 0.0/ -0.1
Width	42.80±0.10
Length	36.40±0.15

The maximum weight of the drive is 16 grams.

The drive will mount in all axes (six directions).

See the illustrations on the following page.

Mechanical dimensions

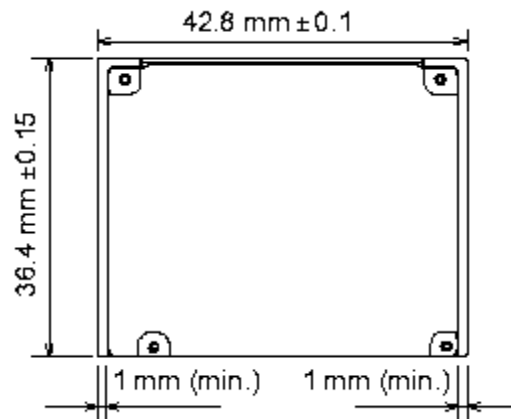
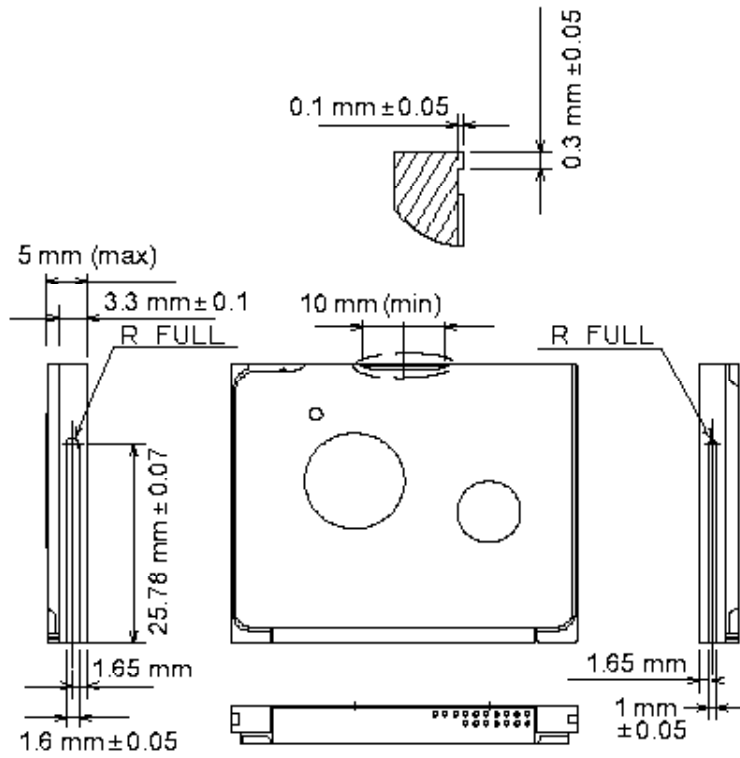

© Copyright Hitachi Global Storage Technologies

Hitachi Global Storage Technologies
5600 Cottle Road
San Jose, CA 95193

Produced in the United States

11/03

All rights reserved Microdrive™ is a trademark of Hitachi Global Storage Technologies.

Microsoft, Windows XP, and Windows are trademarks of Microsoft Corporation in the United States, other countries, or both.

Other product names are trademarks or registered trademarks of their respective companies.

References in this publication to Hitachi Global Storage Technologies products, programs or services do not imply that Hitachi Global Storage Technologies intends to make these available in all countries in which Hitachi Global Storage Technologies operates.

Product information is provided for information purposes only and does not constitute a warranty.

Information is true as of the date of publication and is subject to change. Actual results may vary.

This publication is for general guidance only. Photographs may show design models.

04 November 2003
