



# Product summary

## Ultrastar 18ES

Single-ended/multi-mode SE/LVD

Models: DNES-318350  
DNES-309170



---

### Introducing

IBM's new Ultrastar 18ES offers capacities of 18.1GB and 9.1GB in both single-ended and multi-mode Low Voltage Differential (Ultra2 SCSI). The high reliability and excellent performance of the Ultrastar 18ES are the result of the implementation of a number of advanced disk drive technologies, including GMR head technology, No-ID sector formatting, S.M.A.R.T., and the Drive Temperature Indicator (Drive-TIP) feature.

---

### Applications

- Technical/commercial workstations
- Network servers
- High-end personal computers
- CAD/CAM
- Multimedia
- Transaction processing
- Data mining applications

---

### Features

- 9.1GB & 18.2GB formatted capacity
- Industry standard interface
  - 50 pin Ultra SCSI Fast
  - 68 pin Ultra SCSI Fast Wide
  - 68 pin Ultra2 SCSI Fast Wide
  - 80 pin Ultra2 SCSI SCA-2
- 12.7 -20.2MB/sec sustained data transfer rate
- 159 - 244 Mbits/sec media transfer rate
- Rotational speed 7,200 RPM
- Average seek time 7.0ms (typical read)
- Latency 4.17ms
- 2MB multi-segmented cache buffer
- Low command overhead
- ECC on the fly (EOTF)
- Giant magnetoresistive (GMR) head technology
- No-ID sector formatting
- PRML data channel
- Predictive Failure Analysis (S.M.A.R.T. compliant)
- Drive Temperature Indicator Processor (Drive-TIP) feature

---

### Benefits

- Range of capacities to meet the need for increasing storage requirements
- Fast interface data rates
  - 20MB/sec
  - 40MB/sec
  - 40 & 80MB/sec
  - 40 & 80MB/sec
- High data rate across entire disk surface
- Fast access to data
- Fast data retrieval in single and multi-tasking applications
- Improved data throughput
- High areal density
- More data stored per track, increased sustained data transfer rate
- High reliability and availability

## Connectors

The electrical connectors are located as shown.

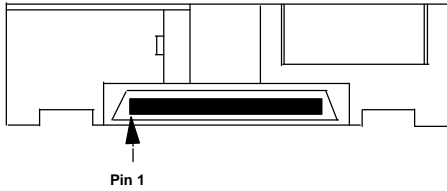

Electrical connectors (rear view) 80 pin SCA models.

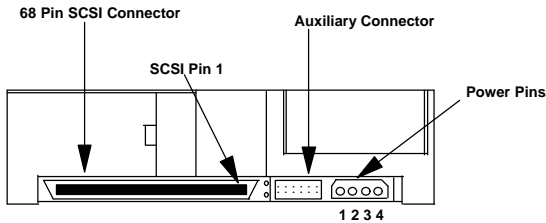

Electrical connectors (rear view) 68 pin models.

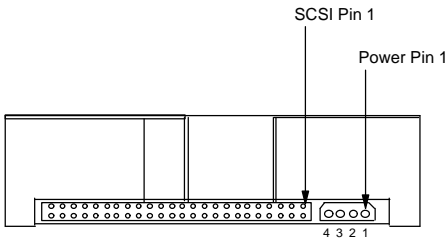

Electrical connectors (rear view) 50 pin models.

Note: See electrical interface specifications for power pin assignment.

Power pin assignment of 50 pin and 68 pin models is shown below.

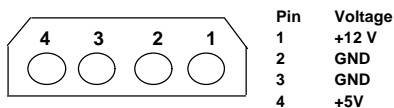

50 pin model power connectors comply with the ANSI SCSI "A" connector specifications, while 68 pin model power connectors comply with the ANSI SCSI "P" connector specifications. 80 pin model power connectors comply with SFF-8046 Revision 2.1.

## Option block

### Jumper settings

Jumper position and function are as shown below. There are two option jumper blocks located on the card of 50 and 68 pin models, J-4 and J-6. 80 pin models have only one option jumper block, J-4.

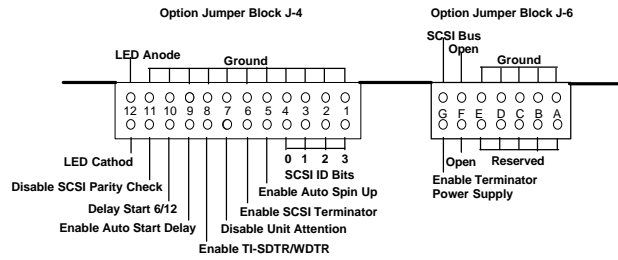

\*80 pin models do not have Option Jumper Block J-6

Jumper settings for single-ended models.

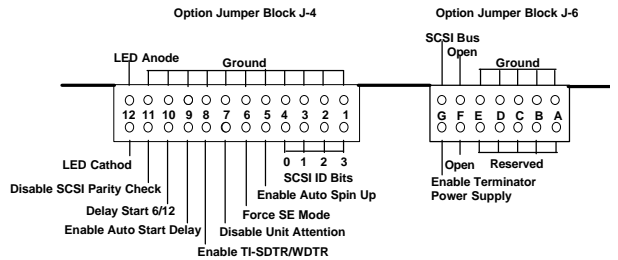

\*80 pin models do not have Option Jumper Block J-6

Jumper settings for LVD (Ultra2 SCSI) models.

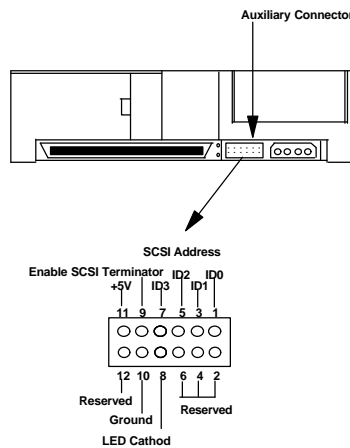

Note: Pin #9 is valid only for single-ended model. LVD/SE multi-mode model has no terminator.

**Jumper setting descriptions**

**SCSI ID (address) settings**

Note: in the address determination tables, “off” means a jumper is not in place and “on “ means a jumper is in place.

Bit 3	Bit 2	Bit 1	Bit 0	Address
off	off	off	off	0
off	off	off	on	1
off	off	on	off	2
off	off	on	on	3
off	on	off	off	4
off	on	off	on	5
off	on	on	off	6
off	on	on	on	7
on	off	off	off	8
on	off	off	on	9
on	off	on	off	10
on	off	on	on	11
on	on	off	off	12
on	on	off	on	13
on	on	on	off	14
on	on	on	on	15

\*Note: The 50 pin model does not use Bit 3 and only SCSI Device IDs 0 through 7 can be assigned.

**Enable Auto Spin Up**

If a jumper is installed in position #5 of J-4 on 50 and 68 pin models, the drive will spin up automatically after a power on reset. If a jumper is not installed, the drive will not spin up unless a START UNIT command is received.

**Disable Auto Spin Up**

If a jumper is not installed in position # 5 of J-4 on 80 pin models, the drive will spin up automatically after a power on reset. If a jumper is installed, the drive will not spin up unless a START UNIT command is received.

**Enable SCSI Terminator**

If a jumper is installed in position #6 of J-4 on Single-ended models, the internal SCSI active terminator on the drive will function.

**Force SE Mode**

If a jumper is installed in position #6 of J-4 on LVD/SE Multi-mode models, the drive will function in Single-ended mode.

**Disable Unit Attention**

Installing a jumper in position #7 of J-4 enables control of the Unit Attention Inhibit bit in Mode Page 0.

**Enable TI-SDTR**

Installing a jumper in position #8 of J-4 on 50 pin models enables Target Initiated Synchronous Data Transfer Request Negotiation.

**Enable TI-SDTR/WDTR**

Installing a jumper in position #8 of J-4 on 68 and 80 pin models enables Target Initiated Wide Data Transfer Request Negotiation and Target Initiated Synchronous Data Transfer Request Negotiation.

**Auto Start Delay/Delay Start 6/12**

The pins at positions #9 and #10 on J-4 control when and how the drive spins up in conjunction with position #5 on J-4. When both Auto Spin Up and Auto Start Delay are enabled, the drive start will be delayed by a period of time multiplied by the drive’s SCSI address. If Auto Spin Up is disabled, these jumpers will be ignored.

**Disable SCSI Parity Check**

Installing a jumper on position #11 of J-4 disables SCSI Parity checking.

**LED pins**

The LED pins are used to drive an external Light Emitting Diode. Up to 30 mA of sink current is provided. The LED Anode must be tied to the current limited +5 V source provided on position #12 on J-4. The LED Cathod is then connected to the pin at position #12 on J-4 to complete the circuit. Refer to the Interface Specification for a more detailed functional description of this pin.



**ATTENTION:** The drive must be protected against electrostatic discharge especially when being handled.

The safest way to avoid damage is to put the drive in an anti-static bag before ESD wrist straps, etc. are removed.

Drives should only be shipped in approved containers. Severe damage can be caused to the drive if the packaging does not adequately protect against the shock levels induced when a box is dropped. Consult your IBM representative if you do not have an approved shipping container.

Note: In the table below, “on” means a jumper is installed and “off” means a jumper is not installed.

Enable/Disable Auto Spin Up	Auto Start Delay	Delay Start 6/12	Feature
Position 5	Position 9	Position 10	Option
off (50/68 pin) on (80 pin)	either	either	Drive will not spin up, requires Start Unit command.
on (50/68 pin) off (80 pin)	off	off	Spin up immediately after POR.
on (50/68 pin) off (80 pin)	on	off	Spin up 6 seconds multiplied by SCSI address after POR.
on (50/68 pin) off (80 pin)	on	on	Spin up 12 seconds multiplied by SCSI address after POR.

**Data organization**

Model	18.2GB	9.1GB
Number of disks	5	3
Number of heads	10	5

**Seek times (in milliseconds)**

Average (typical)	Read	7
	Write	8
Full stroke (typical)	Read	13
	Write	14

**DC power requirement limits**

The following voltage specifications apply at the drive power connector. Connection to the drive should be made in isolated secondary circuits (SELV). No special power on/off sequencing is required.

+5 volt supply	5V ± 5%
+12 volt supply	12V ± 5% <sup>1</sup>

**Power supply current +5VDC**

	18.2GB Pop. mean	9.1GB Pop. mean
Idle average	0.37Amps	0.36Amps
Seek average	0.48Amps	0.47Amps
Start up maximum	0.75Amps	0.75Amps

**Power supply current +12VDC**

	18.2GB Pop. mean	9.1GB Pop. mean
Idle average	0.42Amps	0.29Amps
Seek average <sup>2</sup>	0.93Amps	0.87Amps
Start up maximum	2.00Amps	2.00Amps

Notes:

1. 12V ± 7% is acceptable during spin up, but the spin up time is not guaranteed.

2. Random Seeks at 100% duty cycle.

**Generated ripple at drive power connector**

	Maximum	Notes
+5V DC	250 [mV pp]	0-10 [MHz]
+12V DC	250 [mV pp]	0-10 [MHz]

During drive start up and seeking, 12 volt ripple is generated by the drive (referred to as dynamic loading). If the power of several drives is daisy chained together, the power supply ripple as well as the dynamic loading of other drives must remain within the regulation tolerance window of ± 0.5%. A more desirable method of power distribution is a common supply with separate power leads to each drive.

**Hot Plug/Unplug support**

The 80 pin model supports Hot Plug/Unplug. The 50 and 68 pin models do not.

**SCSI bus connectors**

**SCSI connector vs. models**

Model	50 pin	68 pin	80 pin
SE model	yes	yes	no
LVD /SE multi-mode model	no	yes	yes

**SCSI bus cable**

**Single-ended mode**

The maximum cumulative cable length when using single-ended transceiver should be 3 meters. Implementations that limit the transfer rate to a maximum of 5 Mbyte transfers per second may extend the cumulative cable length

to 6 meters. (ANSI SCSI-3 X3T10/855D Revision 15a).

The maximum cumulative signal path between terminators should be 3.0 meters when using up to 4 maximum capacitance (25pF) devices. The maximum cumulative signal path length between terminators should be 1.5 meters when using from five to eight maximum capacitance devices. (ANSI SCSI-3 FAST-20 X3T10/1071D).

**LVD mode**

The maximum cumulative cable length when using LVD transceiver must be 12 meters. For the details of specification, refer to ANSI SCSI Parallel Interface-2 (SPI-2) T10 Project 1142D Revision 19.

**SCSI bus terminators (optional)**

**Single-ended model**

Single-ended 50 and 68 pin models have active termination. It can be enabled by installing a jumper plug at position #6 of the J-4 jumper block, or by connecting pins #9 and #10 of the auxiliary connector on the 68 pin model. The using system is responsible for making sure that all required signals are terminated at both ends of the bus cable.

**LVD/SE multi-mode model**

68 and 80 pin LVD/SE multi-mode models do not have termination. The using system is responsible for making sure that all required signals are terminated at both ends of the bus cable.

**Terminator power**

Single-ended models supply terminator power to pin #26 of the 50 pin connector and pin #17 and #18 of the 68 pin connector through current limiter and shotky diode when jumper plug is set at position G of the J-6 jumper block. See the "Option Block" section on

page 2 for the jumper setting. LVD/SE multi-mode models do not supply terminator power.

---

### Operating environment

The drive operates within its performance limits when the following environment is maintained.

### Operating conditions

Temperature	5 to 55 [°C] <sup>1</sup>
Relative humidity	8 to 90 [%RH] non-condensing
Maximum wet bulb temperature	29.4 [°C] non-condensing
Maximum temperature gradient	15 [°C/Hour]
Altitude	-300 to 3048 [m]

### Non-operating conditions<sup>2</sup>

Temperature	-40 to 65 [°C]
Relative humidity	5 to 95 [%RH] non-condensing
Maximum wet bulb temperature	35 [°C] non-condensing
Maximum temperature gradient	15 [°C/Hour]
Altitude	-300 to 12,000 [m]

Notes:

1. The system has to provide sufficient ventilation to maintain a surface temperature below 60[°C] at the center of the drive's top cover.
2. Non-operating conditions should not continue beyond one year.

---

### Vibration and shock

#### Operating vibration

The overall RMS (root mean square) level of horizontal vibration is 0.67G RMS. The overall RMS level of vertical vibration is 0.56G RMS.

#### Non-operating vibration

The overall RMS level of vibration is 1.04G RMS.

#### Operating shock

The drive meets the following criteria:

- No data loss with 10G 11msec half-sine shock pulse
- No data loss with 65G 2msec half-sine shock pulse

The shock pulses of each level are applied to the drive, ten pulses for each direction and for all three axes. There must be a minimum of 30 seconds delay between shock pulses. The input level is applied to a base plate where the drive is attached with four screws.

#### Non-operating shock

The drive withstands the following half-sine shock pulse:

- No data loss with 75G 11ms
  - No data loss with 175G 2ms
- The shocks are applied for each direction of the drive for three mutually perpendicular axes and one axis at a time. Input levels are measured on a base plate where the drive is attached with four screws.

#### Rotational shock

The drive withstands the following rotational shock:

- No data loss with rotational shock 18000rad/s<sup>2</sup> 2ms applied around the axis of the actuator pivot.

Note: The actuator is automatically locked at power-off to keep the heads on a landing zone.

---

### Acoustics

The upper limit criteria of the A-weighted sound power levels are given in Bel relative to one pico watt and are shown in the following table. The measurement method is in accordance with ISO7779.

### A-weighted sound power levels

Mode	A-weighted sound power level
Idle	3.8 (typical) 4.2 (maximum)
Operating	4.8 (typical) 5.0 (maximum)

Background power levels of the acoustic test chamber for each octave band are to be recorded. Sound power levels are measured with the drive supported by spacers so that the lower surface of the drive is located 25+/- 3mm height from the chamber desk. No sound absorbing material should be used. The acoustical characteristics of the drive subsystem are measured under the following conditions:

Idle mode: powered on, disks spinning, track following, unit ready to receive and respond to control line commands.

Operating mode: continuous random cylinder selection and seek operation of actuator with a delay for a time period achieving the required seek rate Ns according to the following formula:

$$N_s = 0.4 / (T_t + T_1)$$

where:

Ns = average seek rate in seeks/sec.

Tt = published random seek time.

T1 = time for the drive to rotate by half a revolution.

---

### Electromagnetic compatibility

When installed in a suitable enclosure and exercised with a random accessing routine at maximum data rate, this drive meets the worldwide EMC requirements listed below.

- United States Federal Communications Commission (FCC) Rules and Regulations (Class B), Part 15.

- European Economic Community (EEC) directive number 76/889 related to the control of radio frequency interference and the Verband Deutscher Elektrotechniker (VDE) requirements of Germany (GOP).

**Mechanical specifications**

The Ultrastar 18ES complies with SFF-8301 with one deviation in tolerance of width,  $\pm 0.25\text{mm}$  vs.  $\pm 0.4\text{mm}$ .

**Physical dimensions**

Height (mm)	$25.4 \pm 0.4$
Width (mm)	$101.6 \pm 0.4$
Length (mm)	$146.0 \pm 0.6$
Weight (grams)	630 maximum

**Mounting**

The drive will operate in all axes (6 directions). Performance and error rate will stay within specification limits if the drive is operated in the other orientations from which it was formatted.

The recommended mounting screw torque is 0.6-1.0 Nm (6-10 Kgf.cm). The recommended mounting screw depth is 4 mm maximum for bottom and 4.5 mm maximum for horizontal mounting.

To avoid performance degradation, it is required to mount the drive in the system securely enough to prevent

excessive motion or vibration of the drive at seek operation or spindle rotation, using appropriate screws or equivalent mounting hardware. Consult with the issuer of this specification for actual application if necessary.

Drive level vibration test and shock test are to be conducted with the drive mounted to the table using the bottom four screws.

Refer to the diagrams below for mounting positions and tappings.

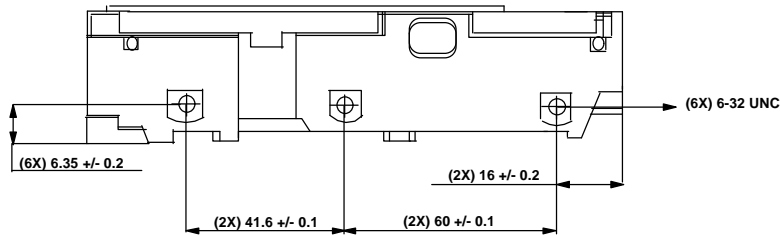

Side view.

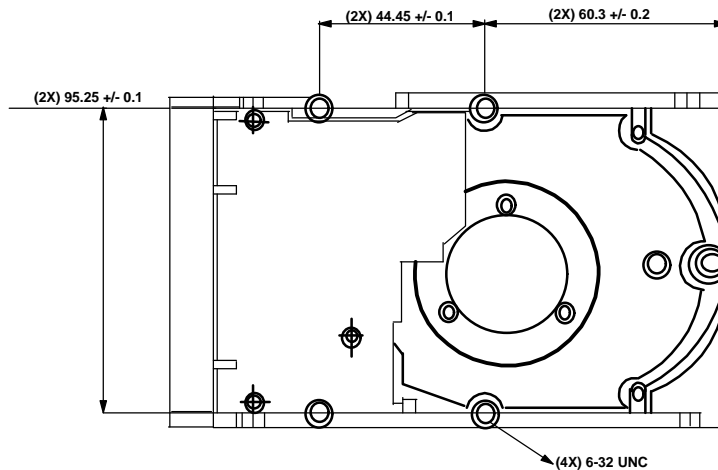

Bottom view.



© International Business Machines Corporation 2000

[www.ibm.com/harddrive](http://www.ibm.com/harddrive)

**IBM Hard Disk Drive Technical Support Center**

Dept. WCN  
3605 Highway 52 North  
Rochester, MN 55901  
Telephone: 888.IBM.5214 or 507.286.5825  
Fax: 507.253.DRIVE  
E-mail: [drive@us.ibm.com](mailto:drive@us.ibm.com)

**Singapore Technical Support Center**

Telephone: 1800.418.9595 or 65.6.418.9595  
E-mail: [drive@sg.ibm.com](mailto:drive@sg.ibm.com)

**IBM Storage Systems Division**

5600 Cottle Road  
San Jose, CA 95193  
[www.ibm.com/storage](http://www.ibm.com/storage)

Asia-Pacific Headquarters: 65.320.1234

European Headquarters: 44.01.705.561.871

Japan Sales Branch Office: 81.46645.1039

Printed in the United States of America  
04-2000  
All Rights Reserved

IBM, Drive-TIP, No-ID, and Predictive Failure Analysis are the registered trademarks of International Business Machines Corporation.

AMP is a trademark of AMP Incorporated.  
DATA MATE is a trademark of AMP Incorporated.  
Molex is a trademark of Molex Incorporated.

Other company, product, and service names may be trademarks or service marks of others.

Produced by the IBM Hard Disk Drive Technical Support Center.

OEM Hard Disk Drive Specifications for  
DNES-318350/DNES-309170 SE model and LVD/SE  
Multi-mode model, revision 0.2

This product summary is not a substitute for the full production specification, which should be used when detailed information is required.

Product Description data represents IBM's design objectives and is provided for comparative purposes; actual results may vary based on a variety of factors. This product data does not constitute a warranty. Questions regarding IBM's warranty terms or methodology used to derive this data should be referred to the IBM Hard Disk Drive Technical Support Center. Data subject to change without notice.

Date: 05 April 2000