



# Quick installation guide

## Travelstar 10GT

### AT/IDE

Models: DCXA-210000  
DCXA-208100



#### Handling precautions

1. *Do not cover the breather hole!* Covering the breather hole may result in loss of data.



2. *Do not press on the drive!* Do not apply any force to the drive during handling or installation.

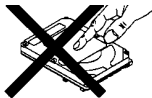

3. Always handle the drive with care to prevent damage from shock, vibration, or electrostatic discharge (ESD).
4. Do not open the static-protective bag containing the drive until required. Static electricity can damage the drive.
5. Turn off and unplug your computer. Remove the cover.
6. When you are installing the drive, touch the static-protective package containing the drive to a grounded, unpainted metal surface for at least two seconds. (This drains static electricity from the package and from your body.)
7. Handle the drive carefully by the edges. Do not touch any exposed printed circuit board.
8. Save your drive packaging material including the ESD bag in the event that the drive has to be returned. Place the drive in an anti-static bag before placing it in the shipping container. The warranty will be void if the drive is not returned in IBM approved packaging.

#### Quick installation procedure

Note: It is advisable to backup all data before proceeding with the installation.

If your system BIOS cannot handle large capacity drives (over 540 MB), you may need to use a disk overlay program such as Ontrack's Disk Manager. The following procedure uses the Ontrack Disk Manager software. Information on obtaining a copy of Ontrack's Disk Manager can be found on the Internet at [www.ibm.com/harddrive](http://www.ibm.com/harddrive).

#### Setting the jumpers

1. In a one drive system, configure your new drive as Master (Device 0) with no jumpers installed.
2. In a two drive system, one drive must be designated as the Master, the other as the Slave (Device 1).
3. When installing the new drive as a Slave, check the Master drive to determine if a jumper change is required to indicate that a Slave drive is present.
4. Consult your manual to see if your computer supports Cable Select before choosing this option.

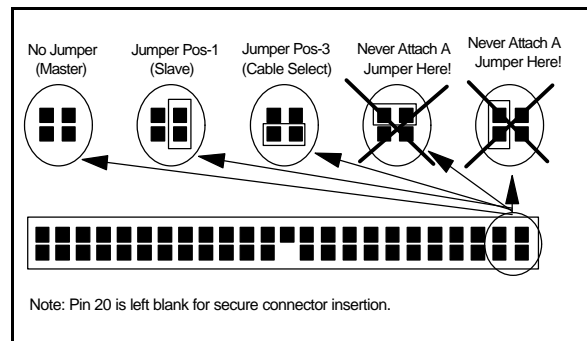

### Attaching the drive

1. Turn off the computer, unplug the power cord, and open the cover.
2. Match pin 1 of the 44 pin cable to pin 1 of the drive interface connector. Pin 1 is usually denoted by a stripe along the edge of the cable.
3. Mount the drive securely.

### Configuring your computer

1. If your computer has a plug-in IDE card with a drive installation procedure, follow the manufacturer's instructions.
2. Plug in the power cord and turn on your computer. Your computer may detect a configuration change and prompt you to proceed to the Setup screen.
3. If your computer does not prompt you to reconfigure, enter your computer's Setup, typically by key selection or keyboard combinations during power-on or during a reboot. Refer to your computer's documentation for the proper key sequence. If the computer fails to boot up, power off, remove the new hard drive and return your system to its original configuration. Reboot and enter your computer's Setup. Follow the directions in step 4, then reattach the new hard drive.
4. Select "Auto Detect" if your computer Setup supports this feature. If your computer does not Auto Detect the drive, select the appropriate UDT (User Definable Type) for the model being installed. Then run Disk Manager.

IBM Model Number	Cylinders	Heads	Sector /Track	Capacity
DCXA-210000	16,383	16	63	10050MB
DCXA-208100	15,880	16	63	8190MB

### Running Disk Manager

1. Boot to operating system from the hard drive or the diskette.
2. Insert the Ontrack diskette.
3. Type DM and press [ENTER] to run Disk Manager.
4. Under "Select an Installation Option" select (E)asy Disk Installation.
5. Select a drive for installation; Disk Manager will partition and format the drive.
6. A status dialog will indicate a successful installation.

If, after complete installation, your system will not boot up, recheck all settings. If the system still fails to boot up, remove the new drive from your system to return to your original configuration and contact technical support.



© International Business Machines Corporation 1999

[www.ibm.com/harddrive](http://www.ibm.com/harddrive)

#### IBM Hard Disk Drive Technical Support Center

3605 Highway 52 North  
Rochester, MN 55901  
Telephone: 888.IBM.5214 or 507.286.5825  
Fax: 507.253.DRIVE  
E-mail: [drive@us.ibm.com](mailto:drive@us.ibm.com)

**Singapore Technical Support Center**  
Telephone: (65)6418.9595 or 1800.418.9595  
E-mail: [drive@sg.ibm.com](mailto:drive@sg.ibm.com)

**IBM Systems Storage Division**  
5600 Cottle Road  
San Jose, CA 95193  
[www.ibm.com/storage](http://www.ibm.com/storage)

Printed in the United States of America  
01-99  
All Rights Reserved

IBM is the registered trademark of International Business Machines Corporation.

Other company, product, and service names may be trademarks or service marks of others.

Produced by the IBM Hard Disk Drive Technical Support Center.

OEM Hard Disk Drive Specification for DCXA-208100/210000, revision 1.0

Product Description data represents IBM's design objectives and is provided for comparative purposes; actual results may vary based on a variety of factors. This product data does not constitute a warranty. Questions regarding IBM's warranty terms or methodology used to derive this data should be referred to the IBM Hard Disk Drive Technical Support Center. Data subject to change without notice.

Date: 11 January 1999