

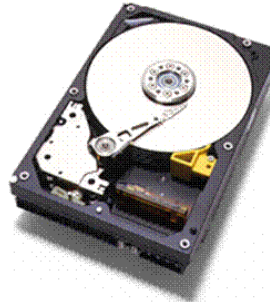

# Product summary

## Deskstar 22GXP

AT/IDE



Models:DJNA-372200, DJNA-371800,  
DJNA-371350, DJNA-370910

---

### Introducing

IBM's latest Deskstar drives are ideal for high-performance desktop users. With capacities of up to 22 GB and a rotational speed of 7200 RPM, users have access to the highest capacities and performance in the industry.

---

### Applications

- High performance Desktop personal computers
- Entry servers
- Entry workstations
- Multimedia applications
- Video editing

---

### Features

- 9.1 GB, 13.5 GB, 18.0 GB & 22.0 GB formatted capacities
- Industry standard interface
  - PIO Mode 4 rates up to 16.6 MB/sec
  - Ultra DMA/66 rates up to 66.6 MB/sec
- 139 - 224 Mb/sec media data transfer rate
- Rotational speed 7,200 RPM
- Average seek time 8.5 ms (read)
- Average latency 4.17 ms
- 1966 KB segmented sector buffer
- ECC on-the-fly
- Power saving modes
- S.M.A.R.T. function support
- Drive Fitness Test (DFT) technology
- Security function support

---

### Benefits

- Range of capacities to meet the need for increasing storage requirements
- Popular interface with excellent performance
- Excellent data rate across disk surface
- Fast access to data
- Fast access to data and improved throughput
- High reliability
- Reduced power consumption
- Protection of user data
- Password protection for sensitive data

**Connectors**

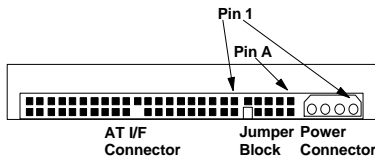

The DC power connector is designed to mate with AMP (part 1-480424-0) using AMP pins (part 350078-4) strip or (part 61173-4) loose piece, or their equivalents. Pin assignments are shown below.

Note: The AT signal connector is a 40 pin connector.

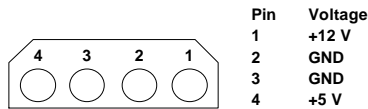

**Cabling**

The maximum cable length from the host system to the drive plus the length of the circuit pattern in the host system should not exceed 18 inches.

For higher data transfer application (greater than 8.3MB/sec), a consideration in system design is recommended to reduce cable noise and/or cross-talk, such as a shorter cable, bus termination, a shielded cable, etc.

For systems operating with Ultra DMA mode 3 or 4, the 80-conductor ATA cable assembly (SFF-8049) should be used.

**Jumper block**

**Jumper settings**

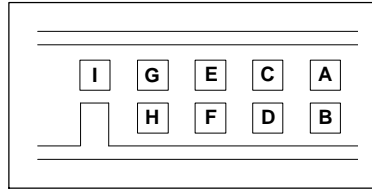

Jumper pins are located between power pins and AT interface pins. Pins A through I are prepared for jumper setting.

**16 head logical architecture**

Master active	A-B and G-H
Slave active	A-B and C-D
Cable Select	A-B and E-F
Master/Slave present	E-F and G-H
Reserved	I

**15 head logical architecture**

Master active	A-C and G-H
Slave active	A-C
Cable select	A-C and E-F
Master/Slave present	A-C, E-F, and G-H
Reserved	I

All other jumper setting patterns are reserved. *Do not make other settings!*

Note: Shipping default is Master active.

**DC power requirements**

Connection to the product should be made in isolated secondary circuits (SELV). The following

voltage specification is applied at the power connector of the drive. There is no special power on/off sequencing required.

**Power supply current**

	DJNA-372200, -371800	
	+5 V pop. mean (in amps)	+12 V pop. mean (in amps)
Idle average	0.25	0.42
Idle ripple (peak to peak)	0.31	0.89
Seek peak	0.49	1.96
Seek average <sup>1</sup>	0.29	0.62
Start up (max.)	0.72	2.04
RND R/W peak	0.78	1.96
RND R/W average <sup>2</sup>	0.35	0.58
Standby average	0.13	0.009
Sleep average	0.052	0.011

	DJNA-371350, -370910	
	+5 V pop. mean (in amps)	+12 V pop. mean (in amps)
Idle average	0.25	0.33
Idle ripple (peak to peak)	0.25	0.55
Seek peak	0.46	1.70
Seek average <sup>1</sup>	0.29	0.50
Start up (max.)	0.71	1.94
RND R/W peak	0.72	1.70
RND R/W average <sup>2</sup>	0.35	0.46
Standby average	0.13	0.009
Sleep average	0.052	0.011

1. Random seeks at 40% duty cycle.
2. Seek duty = 30%, W/R duty = 45%, Idle Duty = 25%.

**Data organization (logical)**

	DJNA-370910	371350	371800	372200
Number of heads	16*/15	16*/15	16*/15	16*/15
Sectors/track	63	63	63	63
Number of cylinders	16,383	16,383	16,383	16,383
Customer usable data bytes	9,115,361,280	13,578,485,760	18,042,716,160	22,605,004,800

\* Shipping default.

**Power supply generated ripple\**

	Maximum	Notes
+5V DC	100 [mV pp]	0-10 [MHz]
+12V DC	150 [mV pp]	0-10 [MHz]

During file start up and seeking, 12 volt ripple is generated by the file (referred to as dynamic loading). If several drives have their power daisy chained together, the power supply ripple plus dynamic loading of other drives must remain within the above regulation tolerance. A common supply with separate power leads to each drive is a more desirable method of power distribution.

To prevent external electrical noise from interfering with the drive's performance, the drive must be held by four screws in a user system frame which has no electrical level difference at the position of the four screws. The user system frame must also have less than +/-300 millivolts peak to peak level difference to the drive power connector ground.



**ATTENTION:** The drive must be protected against electrostatic discharge especially when being handled. The safest way to avoid damage is to put the drive in an anti-static bag before ESD wrist straps are removed.

Drives should only be shipped in approved containers. Severe damage can be caused to the drive if the packaging does not adequately protect against the shock levels induced when a box is dropped. Consult your IBM representative if you do not have an approved shipping container.

**Hot Plug/Unplug support**

Hot plugging/unplugging is not allowed because damage to the file electronics may result if the power supply cable is connected or disconnected while power is being applied to the drive.

**Electromagnetic compatibility**

The drive, when installed in a suitable enclosure and exercised with a random accessing routine at maximum data rate, meets the worldwide EMC requirements listed below.

IBM will provide technical support to assist users in complying with the EMC requirements.

- United States Federal Communications Commission (FCC) Rules and Regulations (Class B), Part 15.
- European Economic Community (EEC) directive number 76/889 related to the control of radio frequency interference and the Verband Deutscher Elektrotechniker (VDE) requirements of Germany (GOP).

**CE Mark**

The Deskstar 22GXP complies with EC directive 879/336/EEC. CE mark for the certification is indicated on the drive label.

**C-Tick Mark**

The Deskstar 22GXP complies with the following Australian EMC standard.

- Limits and methods of measurement of radio disturbance characteristics of information technology equipment, AS/NZS 3548:1995 CLASS-B.

**Environment**

**Operating conditions**

Temperature	5 to 55°C
Relative humidity	8 to 90%RH
Maximum wet bulb temperature	29.4°C
Maximum temperature gradient	15°C/hour
Altitude	-300 to 3048m

**Non-operating conditions**

Temperature	-40 to 65°C
Relative humidity	5 to 95%RH
Maximum wet bulb temperature	35°C
Maximum temperature gradient	15°C/hour
Altitude	-300 to 12,000m

Note: The system has to provide sufficient ventilation to maintain a surface temperature below 60[°C] at the center of the drive's top cover.

**Operating shock**

The drive meets the following criteria.

- No data loss with 10g 11ms half-sine shock pulse.
- No data loss with 65G 2ms half-sine shock pulse.

The shock pulses of each level are applied to the drive, ten pulses for each direction and for all three axes. There must be a minimum of 30 seconds delay between shock pulses. The input level is applied to a base plate where the drive is attached with four screws.

**Non-operating shock**

The drive withstands the following half-sine shock pulse.

- No data loss with 75G 11ms.
- No data loss with 175G 2ms.

The shocks are applied for each direction of the drive for three mutually perpendicular axes and one axis at a time. Input levels are measured on a base plate where the drive is attached with four screws.

**Rotational shock**

The drive withstands the following rotational shock.

- No data loss with rotational shock 18,000 rad/s<sup>2</sup> 2ms applied around the axis of the actuator pivot.

Note: The actuator is automatically locked at power-off to keep the heads on a landing zone.

**Acoustics**

The upper limit criteria of the A-weighted sound power levels are given in Bel relative to one pico watt and are shown in the following table. The measurement method is in accordance with ISO7779.

Mode	A-weighted sound power level [Bel]
Idle	3.8 (typical) 4.2 (maximum)
Operating	4.5 (typical) 4.8 (maximum)

**Command descriptions**

The following commands are supported by the drive:

Commands	(Hex)	P
Check Power Mode	E5	3
Check Power Mode*	98	3
Execute Device Diagnostic	90	3
Flush Cache	E7	3
Format Track	50	2
Identify Device	EC	1
Idle	E3	3
Idle*	97	3
Idle Immediate	E1	3
Idle Immediate*	95	3
Initialize Device Parameters	91	3
NOP	00	3
Read Buffer	E4	1

Read DMA (retry)	C8	4
Read DMA (no retry)	C9	4
Read DMA Queued	C7	5
Read Long (retry)	22	1
Read long (no retry)	23	1
Read Multiple	C4	1
Read Native Max LBA/CYL	F8	3
Read Sectors (retry)	20	1
Read Sectors (no retry)	21	1
Read Verify Sectors (retry)	40	3
Read Verify Sectors (no retry)	41	3
Recalibrate	1x	3
Security Disable Password	F6	2
Security Erase Prepare	F3	3
Security Erase Unit	F4	2
Security Freeze Lock	F5	3
Security Set Password	F1	2
Security Unlock	F2	2
Seek	7x	3
Service	A2	5
Set Features	EF	3
Set Max LBA/CYL	F9	3
Set Multiple Mode	C6	3
Sleep	E6	3
Sleep*	99	3
SMART Disable Operations	B0	3
SMART Enable/Disable Attribute Autosave	B0	3
SMART Execute Off-line Data Collection	B0	3

SMART Read Attribute Values	B0	1
SMART Read Attribute Thresholds	B0	1
SMART Return Status	B0	3
SMART Save Attribute Values	B0	3
SMART Enable/Disable Automatic Off-line Data Collection	B0	3
Standby	E2	3
Standby*	96	3
Standby Immediate	E0	3
Standby Immediate*	94	3
Write Buffer	E8	2
Write DMA (retry)	CA	4
Write DMA (no retry)	CB	4
Write DMA Queued	CC	5
Write Long (retry)	32	2
Write Long (no retry)	33	2
Write Multiple	C5	2
Write Sectors (retry)	30	2
Write Sectors (no retry)	31	2

- Protocol
- 1 : PIO data IN command
  - 2 : PIO data OUT command
  - 3 : Non data command
  - 4 : DMA command
  - 5 : DMA queued command
  - + : Vendor specific command

Note: Commands marked \* are alternate command codes for previously defined commands.

**Signal definition**

Pin	Signal	I/O
01	-RESET	I
02	GND	
03	DD07	I/O
04	DD08	I/O
05	DD06	I/O
06	DD09	I/O
07	DD05	I/O
08	DD10	I/O
09	DD04	I/O
10	DD11	I/O
11	DD03	I/O
12	DD12	I/O
13	DD02	I/O
14	DD13	I/O
15	DD01	I/O
16	DD14	I/O
17	DD00	I/O
18	DD15	I/O
19	GND	
(20)	Key	
21	DMARQ	O
22	GND	
23	-DIOW(*)	I
24	GND	
25	-DIOR(*)	I
26	GND	
27	IORDY(*)	O
28	CSEL	I
29	-DMACK	I
30	GND	
31	INTRQ	O
32	-HIOCS16	O
33	DA01	I
34	-PDIAB /-CBLID	I/O
35	DA00	I
36	DA02	I
37	-CS0	I
38	-CS1	I
39	-DASP	I/O
40	GND	

**Notes:**

1. "O" designates an output from the drive.
2. "I" designates an input to the drive.
3. "I/O" designates an input/output common.
4. The signal lines marked with (\*) are redefined during the Ultra DMA protocol to provide special functions. If the Ultra DMA transfer mode was previously chosen via SetFeatures, these lines change from the conventional to special definitions at the moment the Host decides to allow a DMA burst. The drive becomes aware of this change upon assertion of the -DMACK line. These lines revert back to their original definitions upon the deassertion of -DMACK at the termination of the DMA burst.

	Special definition (for Ultra DMA)	Conventional definition
Write operation	-DDMARDY	IORDY
	HSTROBE	-DIOR
	STOP	-DIOW
Read operation	-HDMARDY	-DIOR
	DSTROBE	IORDY
	STOP	-DIOW

**Mechanical data**

Height (mm)	25.4 ± 0.4
Width (mm)	101.6 ± 0.4
Length (mm)	146.0 ± 0.6
Max weight (grams)	
DJNA-371350, -370910	560
DJNA-372200, -371800	630

**Mounting**

The drive will operate in all axes (6 directions). The drive will operate within the specified error rates when tilted ± 5 degrees from these positions.

Performance and error rate will stay within specification limits if the drive is operated in the other permissible orientations from which it was formatted. Thus, a drive formatted in a horizontal orientation will be able to run vertically and vice versa.

*The recommended mounting screw torque is 0.6 - 1.0 Nm (6-10 Kgf.cm).*

*The recommended mounting screw depth is 4 mm maximum for bottom and 4.5 mm maximum for horizontal mounting.*

If an electrical screw driver is used for mounting screws, a current control type electrical screw driver should be used. A mechanical latch type electrical screw driver is not recommended because of the possibility of mechanical shock higher than specification value which may cause damage to the drive.

The system is responsible for mounting the drive securely enough to prevent excessive motion or vibration of the drive at seek operation or spindle rotation, using appropriate screws or equivalent mounting hardware.

---

**Mechanical dimensions**

---

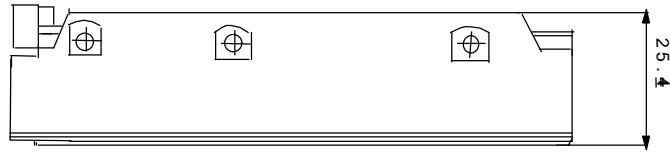

Left

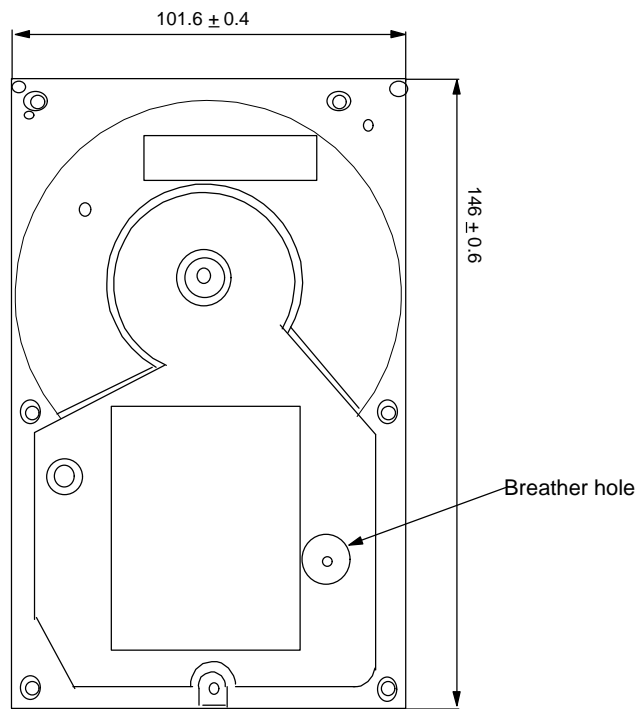

Front

**Mounting hole locations**

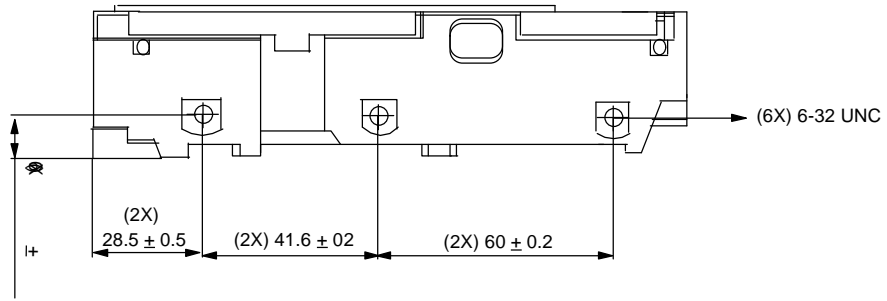

Right

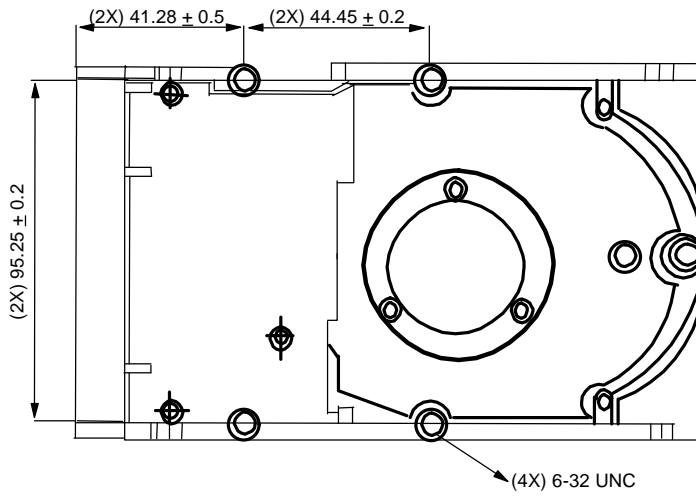

Rear



© International Business Machines Corporation 2000

[www.ibm.com/harddrive](http://www.ibm.com/harddrive)

**IBM Hard Disk Drive Technical Support Center**

Dept. WCN  
3605 Highway 52 North  
Rochester, MN 55901  
Telephone: 888.IBM.5214 or 507.286.5825  
Fax: 507.253.DRIVE  
E-mail: [drive@us.ibm.com](mailto:drive@us.ibm.com)

**Singapore Technical Support Center**

Telephone: (65)6418.9595 or 1800.418.9595  
E-mail: [drive@sg.ibm.com](mailto:drive@sg.ibm.com)

**IBM Storage Systems Division**

5600 Cottle Road  
San Jose, CA 95193  
[www.ibm.com/storage](http://www.ibm.com/storage)

Printed in the United States of America

04-2000

All Rights Reserved

IBM, Drive-TIP, No-ID, and Predictive Failure Analysis are the registered trademarks of International Business Machines Corporation.

AMP is a trademark of AMP Incorporated.  
DATA MATE is a trademark of AMP Incorporated.  
Molex is a trademark of Molex Incorporated.

Other company, product, and service names may be trademarks or service marks of others.

Produced by the IBM Hard Disk Drive Technical Support Center.

OEM Hard Disk Drive Specifications for DJNA-3xxxxx  
3.5-Inch Hard Disk Drive with ATA Interface, Rev. 2.0

This product summary is not a substitute for the full production specification, which should be used when detailed information is required.

Product Description data represents IBM's design objectives and is provided for comparative purposes; actual results may vary based on a variety of factors. This product data does not constitute a warranty. Questions regarding IBM's warranty terms or methodology used to derive this data should be referred to the IBM Hard Disk Drive Technical Support Center. Data subject to change without notice.

Date: 07 April 2000