



Quick installation guide Ultrastar 9LP & 18XP Multi-mode SE/LVD

Models: DGHS-09V, DGHS-09D,
DGHS-18V, DGHS-18D



Handling precautions

1. Do not cover the breather hole! Covering the breather hole may result in loss of data.

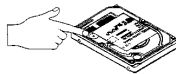

2. Do not press on the drive! Do not apply any force to the drive during handling or installation.

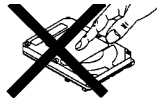

3. Always handle the drive with care to prevent damage from shock, vibration, or electrostatic discharge (ESD).
4. Do not open the static-protective bag containing the drive until required. Static electricity can damage the drive.
5. Turn off and unplug your computer. Remove the cover.
6. When installing the drive, touch a grounded, unpainted metal surface with the static-protective package containing the drive for at least two seconds. (This drains static electricity from the package and from your body.)
7. Handle the drive carefully by the edges. Do not touch any exposed printed circuit board.
8. Save the drive packaging material including the ESD bag in the event that the drive must be returned. Place the drive in an anti-static bag before placing it in the shipping container. The warranty will be void if the drive is not returned in IBM approved packaging.

Quick installation procedure

Note: It is advisable to backup all data before proceeding with the installation.

This procedure may require use of a bootable System Diskette containing FDISK.COM and FORMAT.COM.

Setting the address

1. Each drive on the SCSI bus must have a unique address. Sixty-eight and eighty-pin (Wide SCSI) devices have 16 possible addresses.
2. SCSI address bits 3 (68- & 80-pin models only), 2, 1, and 0 of the 32-pin Option Jumper Block are used to select the SCSI device ID.

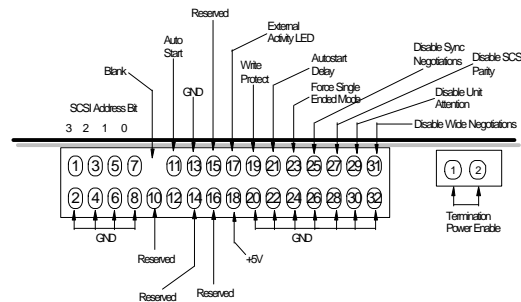
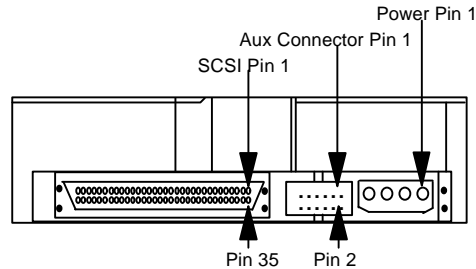

Note In the table below, "off" means a jumper is not in place and "on" means a jumper is in place.

Bit 3	Bit 2	Bit 1	Bit 0	Address
off	off	off	off	0
off	off	off	on	1
off	off	on	off	2
off	off	on	on	3
off	on	off	off	4
off	on	off	on	5
off	on	on	off	6
off	on	on	on	7
on	off	off	off	8
on	off	off	on	9
on	off	on	off	10
on	off	on	on	11
on	on	off	off	12
on	on	off	on	13
on	on	on	off	14
on	on	on	on	15

Attaching the drive

1. Turn off the computer, unplug the power cord and open the case.
2. If the DGHS drive is the only device on the SCSI cable, attach it to the end of the cable furthest from the controller. (Note that the using system is responsible for making sure that all required signals are terminated at both ends of the cable.)
3. Select the other option jumpers as required by your computer.
4. Attach the power connector.

Mounting the drive

1. Mount the drive securely, using the appropriate brackets or rails, in any axes, using four 6-32 UNC metric screws in the bottom or side mounting holes.
2. The maximum screw insertion depth for mounting is 3.8 mm (.15 in).

Configuring your computer

1. Plug in the power cord, insert the System Diskette and power on your computer. Your computer may detect a configuration change and prompt you to proceed to the Setup screen. If so, proceed to step 3.
2. If your computer does not prompt you to enter reconfiguration, enter your computer's Setup, typically by key selection or keyboard combinations during power-on or during a reboot. Refer to your computer's documentation for the proper key sequence.
3. Follow the Setup menu to configure your computer with your new SCSI drive. It may be necessary to restart your computer for the changes to take effect.

Partitioning and formatting (using DOS 5.0 or later)

Caution: Be sure that you select the correct hard drive. Partitioning and formatting will erase all data.

1. At the DOS prompt type FDISK, press [ENTER], and follow the instructions on the screen.
2. To format the primary system drive, type FORMAT C:/S at the DOS command prompt and press

[ENTER]. The /S parameter makes C: the operating system startup drive.

3. To format a second drive (not C:), type FORMAT X: (where X is the drive letter assigned by FDISK) at the DOS prompt and press [ENTER]

4. Remove the diskette and restart your computer. The installation is complete.

If your system will not boot up after complete installation, recheck all settings. If the system still fails to boot up, remove the new drive to return the system to its original configuration and call the IBM Hard Disk Drive Technical Support Center.



© International Business Machines Corporation 1999

www.ibm.com/harddrive

IBM Hard Disk Drive Technical Support Center
 Dept. D8M
 3605 Highway 52 North
 Rochester MN 55901
 Telephone: 888.IBM.5214 or 507.286.5825
 Fax: 507.253.DRIVE
 E-mail: drive@us.ibm.com

Singapore Technical Support Center
 Telephone: 1800.418.9595 or 65.6.418.9595
 E-mail: drive@sg.ibm.com

IBM Systems Storage Division
 5600 Cottle Road
 San Jose CA 95193
www.ibm.com/storage

Asia-Pacific Headquarters: 65.320.1234
 European Headquarters: 44.01.705.561.871
 Japan Sales Branch Office: 81.46645.1039

Printed in the United States of America
 01-99
 All Rights Reserved

IBM is the registered trademark of International Business Machines Corporation.

Other company, product, and service names may be trademarks or service marks of others.

Produced by the IBM Hard Disk Drive Technical Support Center.

Ultrastar 18XP/9LP Hardware/Functional Specification, version 4.50
 Ultrastar 18XP/9LP Parallel SCSI Disk Drive Logical Interface Specification, version 6.0
 Ultrastar 18XP/9LP Parallel SCSI Disk Drive Logical Interface Specification addendum, version 6.0

Product Description data represents IBM's design objectives and is provided for comparative purposes; actual results may vary based on a variety of factors. This product data does not constitute a warranty. Questions regarding IBM's warranty terms or methodology used to derive this data should be referred to the IBM Hard Disk Drive Technical Support Center. Data subject to change without notice.

Date: 8 January 1999