



# Ultrastar 9ZX DGVS-39110

**Models:** *SCSI-3 FAST20 (68pin Single-Ended or Differential)*  
*SCSI-3 FAST20 (80pin Single-Ended SCA-2)*  
*SCSI-3 FAST40 (68 & 80pin (L)ow (V)oltage (D)ifferential)*

IBM OEM has introduced a new range of drives intended for advanced storage applications which demand fast access to large amounts of data.

The drives spin at 10,020 rpm, have an EPRML channel, embedded sector servo, S.M.A.R.T and media data rate 16.1-25.6MB/s.

---

## Applications

- Technical/commercial workstations
- Network servers
- Mass storage arrays
- High end personal computers
- Large scale imaging and graphics
- Video servers
- Video editing



---

## Features

- **9.11GB formatted capacity (512 byte/sector)**
- **Industry standard interface**
  - 68 pin ANSI SCSI-3
  - 80 pin ANSI SCSI-3
- **16.1-25.6 MB/s media data rate (instantaneous)**
- **10.5-17.0 MB/s media data rate (functional)**
- **Rotational speed 10,000 RPM**
- **Average seek time 6.3ms (9.11GB) 7.5ms (18.22GB)**
- **Latency 3.0 ms**
- **1MByte multi-segmented dual port data buffer**
- **Low command overhead** ● **Read ahead caching**
- **ECC on the fly (EOTF)**
- **Industry standard mounting**
- **Predictive Failure Analysis (S.M.A.R.T. Compliant)**

---

## Benefits

- *Range of capacities to meet the need for increasing storage requirements*
- *Fast interface data rates*
  - 20MB/sec data transfer speed (narrow)
  - 40MB/sec (Fast 20) & 80MB/sec (Fast 40) data transfer speed
  - 40MB/sec (Fast 20) & 80MB/sec (Fast 40) data transfer speed
- *High data rate across entire disk surface*
- *Fast access to data*
- *Fast data retrieval in single and multitasking applications*
- *Improved data throughput*
- *Ease of installation*
- *High reliability and availability*

## Connectors

The electrical connectors are located as shown.

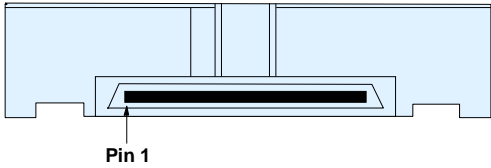

Electrical Connectors (rear view) 80 Pin SCA models

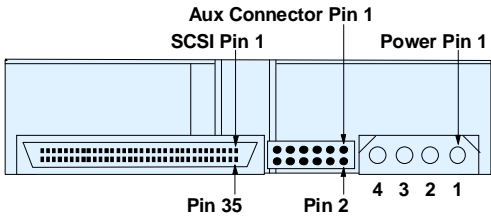

Electrical Connectors (rear view) 68 Pin models

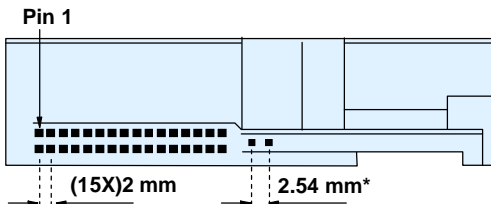

Jumper Pin locations (front view) - all models

\* Not available on 80 Pin SCA

**Note:** See electrical interface specifications for power pin assignment.

The DC power connector is designed to mate

with AMP part 1-480424 (using AMP pins P/N 350078-4). Equivalent connectors may be used.

Pin assignments are shown below, as viewed from the end of the drive.

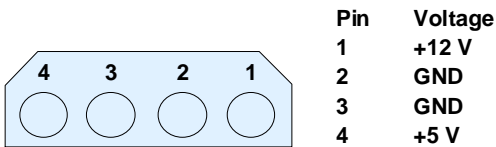

## Option Block

### Jumper Settings

Jumper position and function are as shown below. Pin pitch is 2mm. Termination power enable 2.54mm pitch.

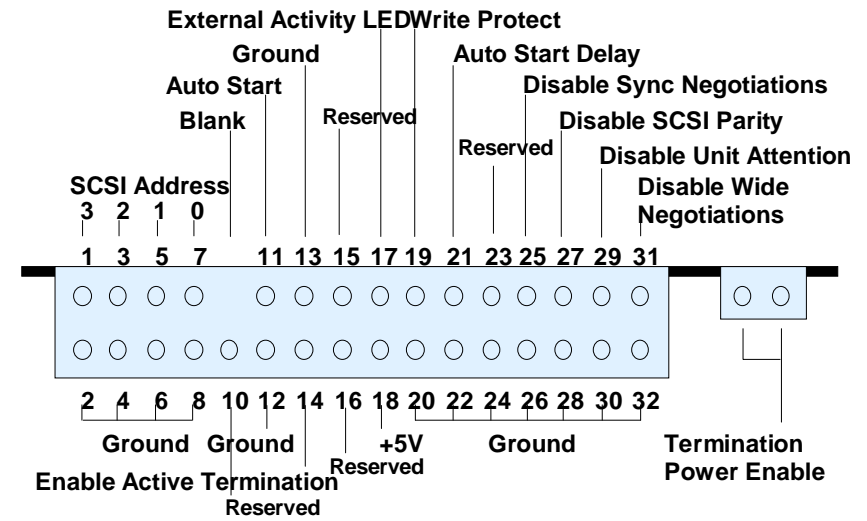

68 Pin Single Ended Front Option Block and TermPower Block.  
68 Pin Differential Option Jumper Block.

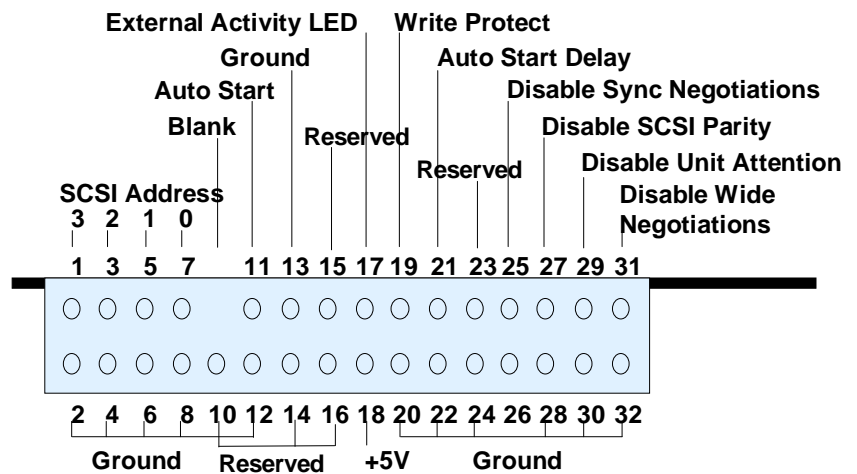

80 Pin SCA-2 Front Option Jumper Block.

## 68 Pin Auxiliary Connector

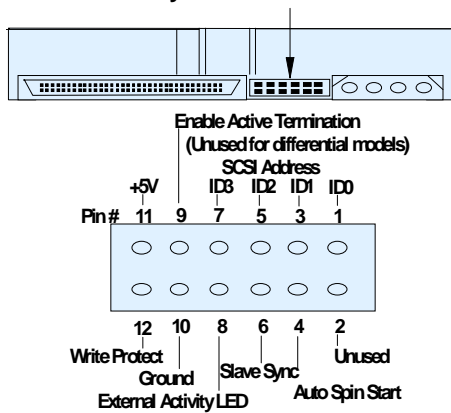

### SCSI ID (Address) Pins

**Note:** In the address determination tables, "off" means jumper is not in place and "on" means jumper is in place.

Bit 3	Bit 2	Bit 1	Bit 0	Address
off	off	off	off	0
off	off	off	on	1
off	off	on	off	2
off	off	on	on	3
off	on	off	off	4
off	on	off	on	5
off	on	on	off	6
off	on	on	on	7
on	off	off	off	8
on	off	off	on	9
on	off	on	off	10
on	off	on	on	11
on	on	off	off	12
on	on	off	on	13
on	on	on	off	14
on	on	on	on	15

### Address Determination 68 and 80 pin models

#### Auto Start and Delay Pins

The Auto Start and Auto Start Delay pins control when and how the drive can spin up and come ready. When configured for Auto-Startup, the motor spins up after power is applied without the need of a SCSI Start Unit command. For no Auto-Start, a SCSI Start Unit command is required to make the drive spin and be ready for media access operations. When in Auto-Start mode, the drive will delay its start time

by a period of time multiplied by its own SCSI address.

68 pin interface model		Drive Behaviour	
Auto Start Delay	Auto Start	Auto Start	Delay(sec) Multiplier
off	off	No	N/A
off	on	Yes	0
on	off	Yes	10
on	on	Yes	4

#### Auto-Startup Modes selectable by Auto-Start/Delay Pin Combinations.

Pins (80 interface pin model)		Drive Behaviour	
Auto Start Delay	Auto Start	Auto Start	Delay(sec) Multiplier
off	off	Yes	0
off	on	No	N/A
on	off	Yes	10
on	on	No	N/A

#### Auto-Startup Modes selectable by Auto-Start/Delay Pin Combinations.



**PACKAGING:** The drive must be protected against electrostatic Discharge especially when being handled. The safest way to avoid damage is to put the drive in an anti static bag before ESD wrist straps etc. are removed.

Drives should only be shipped in approved containers, severe damage can be caused to the drive if the packaging does not adequately protect against the shock levels induced when a box is dropped. Consult your IBM marketing representative if you do not have an approved shipping container.

#### External Activity (LED) Pins

The LED pins can be used to drive an external Light Emitting Diode. Please refer to the LED pin section of the Ultrastar Interface Specification for a detailed functional description of this pin, which is controlled by Mode Select (Page 0). Up to 33mA ( 5%) of TTL level LED drive capability is provided. Current limiting for the LED is provided on the electronics card. The LED Anode may be tied to the + 5V source provided

on pin 18 of the Front Option Jumper Block, pin 11 of the Auxiliary connector on the 68 pin Unitised connector or the 5V power source on the 80 pin SCA model. The LED Cathode is then connected to the EXTERNAL ACTIVITY Pin to complete the circuit.

**Note:** 68 pin and 80 pin SCA SCSI models have two sets of pins, a set on the front and a set on the back, that are connected to the same LED driver circuit. The combined drive capability is stated above.

#### Write Protect Pin

If the Write Protect pin is jumpered to ground, the drive will prohibit SCSI commands that alter the customer data area portion of the media from being performed. The state of this pin is monitored on a per command basis. See the Ultrastar interface specification for functional details.

### Disable T.I. Sync. Negotiation Pin

If a Disable Target Initiated Synchronous Negotiation pin is grounded then an Initiator is required to start a negotiation handshake if Synchronous and/or 'Wide' (Double Byte) SCSI transfers are desired. Please refer to the Ultrastar 9LP & 18XP Interface Specification for more details on this feature.

### Disable SCSI Parity Pin

Grounding this pin will disable SCSI Parity checking.

### Disable Unit Attention Pin

Grounding this pin will disable the drive from building Unit Attention Sense information for commands immediately following a Power On Reset (POR) or SCSI Bus Reset. Any pending Unit Attention conditions will also be cleared at POR or SCSI Reset times.

### Disable Wide Negotiations

Jumpering pin 31 to 32, will cause the 68 pin SE, 80 pin SCA, or the 68 Differential to operate in a Single Byte mode. The drive will not negotiate for 'Wide' (Double Byte) operation.

### Enable Active Termination

Single Ended 68 pin models are available with on card SCSI Bus Active Terminators. The Active Termination feature can be enabled by installing a jumper between pins 13 and 14 of the Front Option Jumper Block or connecting pins 9 and 10 of the Auxiliary Connector on 68 SCSI pin models. SCA-2 80 pin has no termination.

### Data Organisation

Model	9.11GB
Disks	5
User data heads	10

#### Seek times (in milliseconds)

Single Cylinder (Read)	0.7
(Write)	1.8
Average(weighted)(Read)	6.5
(Write)	8.3
Full stroke (Read)	17.0
(Write)	18.8

#### User capacity for several block lengths

##### 9.11 GB Models

User bytes/ logical block	formatted capacity (bytes)	logical blocks/ drive
512	9,128,893,440	17,829,870
514	9,066,784,212	17,639,658
520	9,085,299,600	17,471,730
522	908,003,444	17,394,702
524	9,086,131,704	17,339,946
528	9,110,505,888	17,254,746
536	9,119,865,264	17,014,674
688	9,385,705,632	13,642,014
732	9,450,297,144	12,910,242

### Mode Select Options

Certain parameters are alterable using the SCSI 'Mode Select' command. This allows certain drive characteristics to be modified to optimise performance on a particular system. Refer to the Ultrastar SCSI Functional Specification for a detailed definition of Mode Select parameters.

### DC Power Requirement Limits

The following voltage specification apply at the drive power connector. There are no special power on/off sequencing requirements.

+5 Volt Supply	±5.0%(during run and spin up)
+12 Volt Supply	±5.0% (during run) +5.0% / -7.0%(during spin up)

#### 9.11GB Power Supply Current +5VDC

Notes	Population Mean
Idle average	0.78 Amps <sup>1</sup>
R/W average	1.03 Amps
R/W pulse peak	1.25 Amps

#### 9.11GB Power Supply Current +12VDC

Idle average	0.45 Amps
Seek peak	2.07 Amps
Spin-up	1.6 Amps <sup>2</sup>

#### Notes:

1. 5 Volt Current is given with termination power provided by the using system.
2. The current at start is the total 12 volt current required (i.e.. the motor start current, module current and voice coil retract current).

#### Externally generated ripple

Power Supply Generated Ripple as seen at drive power connector.

Voltage	Maximum	Notes
+5V DC	200mV peak-to-peak	0-20 MHz
+12V DC	200mV peak-to-peak	0-20 MHz

During drive start up and seeking, 12 volt ripple is generated by the drive (referred to as dynamic loading). If several drives have their power daisy chained together then the power supply ripple plus other drives dynamic loading must remain within the regulation tolerance window of ±5%. A common drive supply with separate power leads to each drive is a more desirable method of power distribution.

---

## Hot plug/unplug support

---

The drives do support Hot Plug/Unplug -refer to Ultrastar 9LP & 18XP Hardware/ Functional Specification for more details. Hot plugging the SCSI bus may cause glitches on the bus. To minimise the chance of glitching, it is recommended to plug in the SCSI bus before the power is applied.

During hot plugging, the supplies must not go over the upper voltage limits. This means that proper ESD protection must be used during the plugging event. Care must be taken not to exceed shock limits whilst hotplugging or unplugging.

### 68 Pin SCSI Signal Connector

68 pin models use an MOLEX connector (PN 87360-0001) that is compatible with the ANSI SCSI "P" connector specifications. It can transfer data in both 8 bit (narrow) and 16 bit (wide) modes. Both single-ended and differential versions are supported. The differential 68 pin models are electrically compatible with differential 50 pin models and other 50 pin differential SCSI products and therefore can coexist on the same bus. In order to do so, the differences in connector types would need to be accounted for in the cable. Connecting 68 and 50 pin single-ended models to the same bus can also coexist. Differential and single-ended models do not work connected to the same bus.

### 80 Pin (Single Connector Attachment)

80 pin SCA-2 models use an AMP connector (PN 5-917593-9) that is compatible with the specification of: 'Single Connector Attachment for Small SCSI Disk Drives' SFF 8046. It can transfer data in both 8 bit (Narrow) and 16 bit (wide) modes.

**Note:** The "SCA-2" connector is not mechanically compatible with the 50 pin "A" connector or the 68 pin "P" connector as defined in the ANSI SCSI standard. This connector is intended for direct backplane attachment and is not intended to be cable attached to the bus.

### SCSI Bus Cable

Single-ended models permit cable lengths of up to 6 metres (19.68 feet). It should be noted however that users who plan to use 'Fast' data transfers with single-ended models should follow all of the ANSI SCSI guidelines for single-ended 'Fast' operations. This may include a cable length of less than 6 metres.

SCSI 3 Fast 20 models can be cable connected to a 3 metre (9.8 feet) cable when a maximum of 4 devices are attached, and a 1.5 metre (4.9 feet) cable with up to 8 devices attached.

SCA-2 connector models are not designed for direct cable attachment due to the combination of power and SCSI bus signals. 'Fast & Fast 20' data transfers with SCA models should follow all of the ANSI SCSI guidelines.

Differential models permit cable lengths of up to 25 metres (82.02 feet). Cables must meet the requirements for differential cables as set forth in the ANSI SCSI standard under 'Cable Requirements -Differential Cable'.

The ANSI SCSI standard states that any stub from main cable must not exceed 0.1 metres for single-ended cables and 0.2 metres for differential cables. Ultrastar 9ZX has a maximum internal stub length of 0.05 metres on all 'single-ended' SCSI signals, and 0.1 metres on all 'differential' SCSI signals. To remain compliant with the standard the SCSI bus cable must not add more than 0.05 metres additional stub length to any of the single-ended SCSI signals or 0.10 metres to any differential SCSI signals.

---

## Models

---

DGVS Model No.	Capacity GB (at 512 Byte)	SCSI Pins/ Connector Type	SCSI Electrical Signal Type
09U	9.11	68	SEFW
09X	9.11	68	DFW
09Y	9.11	80 SCA-2	SEFW

### Notes:

"SEF" stands for Single Ended Fast

"SEFW" stands for Single Ended Fast Wide

"DFW" stands for Differential Fast Wide  
68 pin SCSI connector models offer an 8/16 bit SCSI bus using the SCSI "P" connector which supports Wide data transfers.

80 pin SCSI connector models offer an 8/16 bit SCSI bus using the SCA connector.

All models support Fast SCSI data transfers and the U, X and Y models also support SCSI-3 FAST 20 data transfer.

---

### SCSI Bus Terminators (Optional)

---

For those drives having the Active Termination feature, this function can be enabled by installing a jumper between pins 13 and 14 of the Front Option Jumper Block or connecting pins 9 and 10 of the Auxiliary Connector on 68 SCSI pin models. The using system is responsible for making sure that all required signals are terminated at both ends of the cable.

80 pin SCA models do not have internal SCSI bus terminators.

Some external terminator possibilities for single-ended cabled systems are listed below:

---

#### 68 Pin Model Terminators

---

Data Mate  
DM2050-02-68S  
DM2050-02-68R

---

#### *Single-ended SCSI Terminators*

Differential models do not have internal SCSI bus terminators. Some terminator possibilities are shown below:

---

#### 68 Pin Model Terminators

---

Data Mate DM2050-01-68D

---

#### *Differential SCSI Terminators*

**Note:** A Meritec model 940900-4 or a DataMate DM5000-5068-11 can be used to connect a 68 pin connector to a 50 pin connector. The drive will now perform 8 bit transfers.

### SCSI Bus Termination Power

Termination power is optionally provided for systems that desire to use it. In order to use the termination power, the user needs to install a jumper between pins 1 and 2 of the TermPower Block. The jumper should only be installed on one device, which should be the last device on the SCSI bus. 68 pin models can source up to 2.0 Amps of current at 5.0 Volts ( $\pm 5\%$ ) for termination power.

### SCSI Bus Termination Power Short Circuit Protection

The ANSI SCSI specification recommends for devices that optionally supply TERMPWR, to include current limited protection for accidental short circuits. It also recommends that the maximum current available for TERMPWR should not exceed 2 Amps. UL has a different requirement that they call the 8 Amp rule. This rule states that when a power source leaves an enclosure (like SCSI TERMPWR in the SCSI cable), it must trip 8 Amps of current within 1 minute. The drive limits current to 2.0 Amps through the use of a resettable fuse mounted on the electronic card. Systems may also provide short circuit protection for drive supplied TERMPWR by limiting the current of the 5v power it supplies to the drive.

---

### Operating Environment

---

The drive operates within its' performance limits when the following environment is maintained. Product life calculations are based on the nominal environment for a typical application.

---

#### Humidity

Operating	5% to 90% non-condensing
Storage	5% to 90% non-condensing
Shipping	5% to 95% (applies at the packaged level)

---

#### Wet Bulb Temperature

Operating and Storage	80 F (26.7°C) maximum
Shipping	85 F (29.4°C) maximum

---

#### Elevation

Operating	-1000 to 10000 feet (-304 to 3048 meters)
Shipping/Storage	-1000 to 40000 feet (-304 to 12192 meters)

---

#### Temperature

Operating ambient	41 to 122°F (5 to 50°C)
Operating disk enclosure	41 to 149°F (5 to 65°C)
Shipping	-40 to 149°F (-40 to 65°C)
Storage	34 to 149°F (1 to 65°C)

---

#### Temperature Gradient

Operating	36°F (20°C) per hour
Shipping/Storage	Below condensation

---

These temperature limits are extremely important and must not be exceeded at the worst case drive and system operating conditions with the drive randomly seeking, reading and writing.

## Start and Stop Times

Time	Nominal	Maximum
Models	9.11GB	9.11GB
Power Up	2.5	3.0
Start-up	16.5	30
Spin-up	10.5	15
Spindle Stop	15	15

All times in seconds

## Bring-up Sequence Times and Stop Time

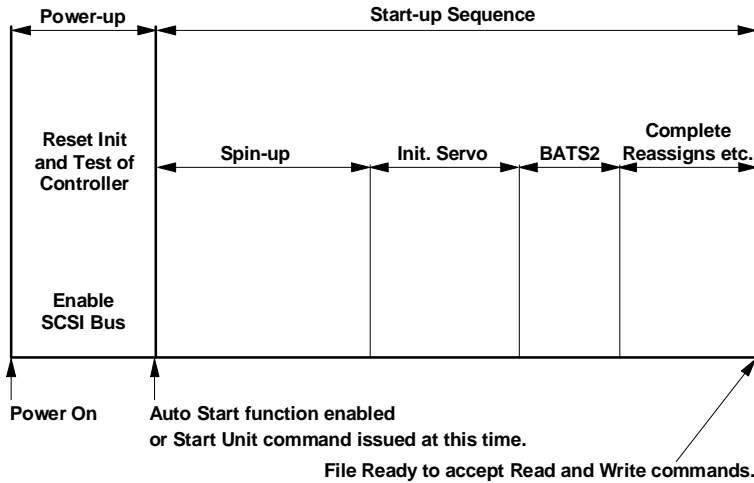

**Note:** If a RESET is issued before the drive comes ready the power on sequence will start again. In all other cases when a RESET is issued the present state of the motor is not altered.

**WARNING:** This disk drive can be damaged by Electro-Static Discharge, please follow recommended ESD procedures before unpacking or handling the drive. Ask your Dealer for details if you need assistance.

**Note:** BATS is the abbreviation for Basic Assurance Tests. Start-up sequence spins up the spindle motor, uploads code, performs BATS2 (verifies read/write hardware), resumes "Reassign in Progress" operations, and more. For more information on the start-up sequence, refer to the Ultrastar 9LP & 18XP Interface Specification.

## Mechanical Specifications

**Weight**  
9.11GB Approx 1.91 pounds (0.87 Kg)

Dimensions	Inches	S.I.Metric
Height		
9.11GB	1.63 in	42.0 mm
Width	4.00 in	101.85 mm
Depth	5.75 in	147.0 mm

## Vibration and Shock

### Operating/Nonoperating Vibration

Due to the complexity of this subject we recommend that users contact the Distributor to discuss how to perform the required measurements if they believe this to be an area which requires evaluation.

### Operating Shock

No permanent damage will occur to the drive when subjected to a 10 G half sine wave shock pulse of 11 milliseconds duration. The shock pulses are applied in each of three mutually perpendicular axis, one axis at a time.

### Nonoperating Shock Translational Shock

No damage will occur if the unpackaged drive is subjected to a square wave shock less than 35 Gs applied to all three axis for a period of 20 milliseconds, one direction at a time. Additionally, no damage will occur if the unpackaged 9.11GB drive is not subjected to an 2 millisecond half sine wave shock greater than 135Gs applied to all three axis, one direction at a time.

### Rotational Shock

The actuator will remain latched in the disk landing zone if the unpackaged drive is subjected to a 2ms half sine pulse shock of 14,000 radians per second squared or less applied to all three axis, one direction at a time.

## Clearances

A minimum of 2mm clearance should be given to the bottom surface except for a 10mm maximum diameter area around the bottom mounting holes.

There should be 7mm of clearance between Ultrastar drives that are mounted with their top sides facing each other. Drives from other manufacturers may require additional spacing due to stray magnetic fields.

For proper cooling it is suggested that a minimum clearance of 7 mm be provided under the drive and on top of the drive.

## Mounting

Refer to Ultrastar 9ZX Hardware/Functional Specification "Drive Mounting Guidelines" for more details on how to mount the drive.

The drive can be mounted with any surface facing down. The drive has both side and bottom mounting holes. Refer to diagrams below for the location of these mounting holes for each configuration.

*The maximum allowable penetration of the mounting screws is 3.8 mm. Screws longer than 3.8 mm may cause permanent damage to the drive.*

The recommended torque to be applied to the mounting screws is 0.8 Newton metres 0.2 Newton metres.

## Grounding requirements of the disk enclosure

The disk enclosure is at Power Supply ground potential. It is allowable for the user mounting scheme to common the Disk Enclosure to Frame Ground potential or to leave it isolated from Frame Ground.

The drives mounting frame must be within 150 millivolts of the drives power supply ground. At no time should more than 35 milliamps of current (0 to 100 Mhz) be injected into the disk enclosure.

## Temperature Measurements

The following is a list of measurement points and their temperature (maximum and reliability). Maximum temperature must not be exceeded at the worst case drive and system operating conditions with the drive randomly seeking, reading and writing. Reliability temperatures must not be exceeded at the nominal drive and system operating conditions with the drive randomly seeking, reading and writing.

### Maximum and Reliable Operating Temperature Limits

	Maximum	Optimum
Disk Enclosure Top	149°F(65°C)	122°F(50°C)
Disk Enclosure Bottom	149°F(65°C)	122°F(50°C)
Channel Module <sup>1</sup>	203°F(90°C)	167°F(80°C)
SCSI Module	194°F(80°C)	158°F(60°C)
Microprocessor Module	176°F(95°C)	140°F(75°C)
Controller Module	194°F(100°C)	158°F(75°C)
Spindle Motor Driver Module	194°F(90°C)	158°F(80°C)

**Note:** The diagrams below define where measurements should be made. Showing where the modules are located on the bottom side of the card and the measurement locations on the bottom of the or top of the casting. There must be sufficient air flow through the drive so that the casting and module temperature limits defined above are not exceeded.

### Module Temperature Measurement Notes:

1. Centre on the top surface of the module.
2. If copper tape is used to attach temperature sensors, it should be no larger than 6 mm square.
3. A thermal sensor is fitted to the electronics card. Several temperature thresholds are continuously monitored and the results updated into the drive log. This is used to provide a thermal history and does not interrupt drive operation.

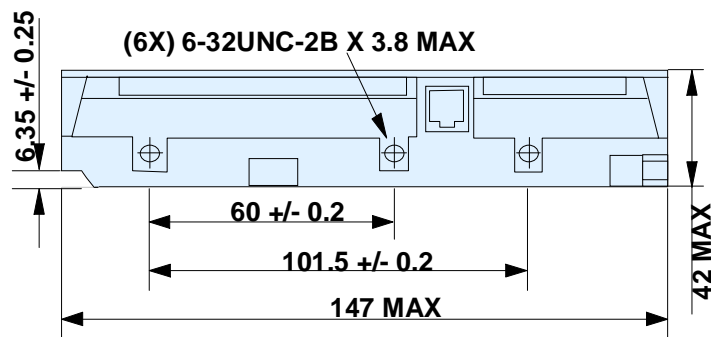

Location of side mounting holes.

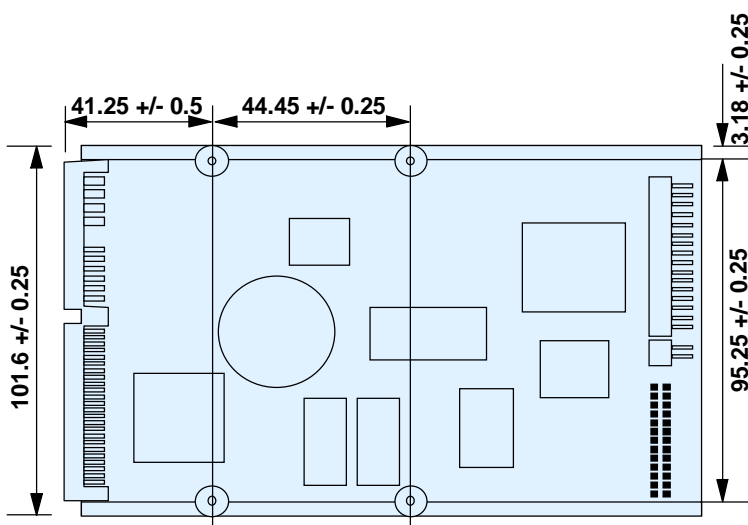

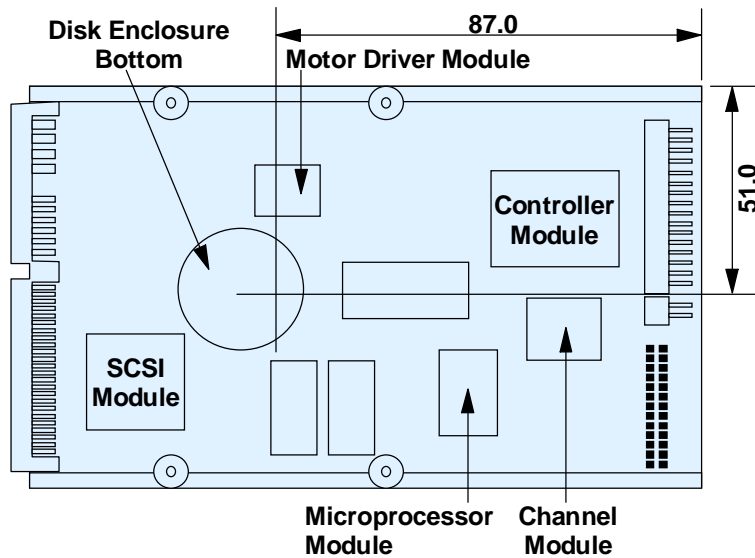
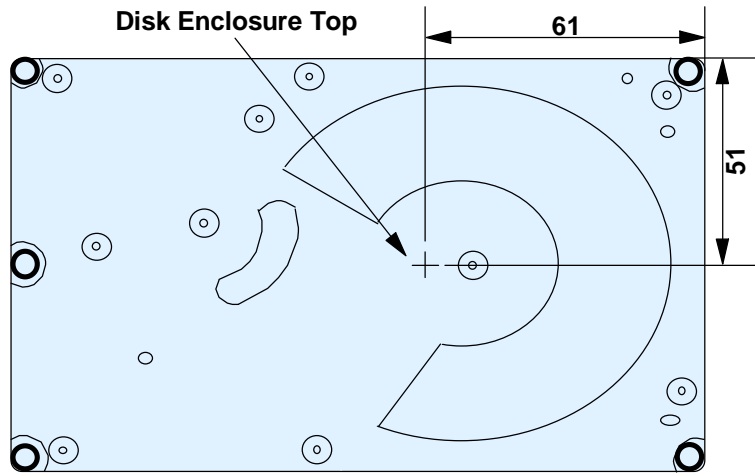

**IBM OEM Europe**

PO Box 41  
North Harbour  
Portsmouth  
Hampshire  
PO6 3AU  
United Kingdom  
Telephone: (44) 1705 561000

**IBM Corporation**

Storage Systems Division  
5600 Cottle Road  
San Jose, CA 95193  
(408) 256-8000

Japan Headquarters: (81) 466-45-1384

Asia-Pacific Headquarters: (65) 320-1503

Internet access at:  
<http://www.ibm.com/storage/hddtech>

Registered in England: No. 741598  
Registered Office: PO Box 41, North Harbour,  
Portsmouth, Hampshire PO6 3AU.

UK company-wide registration to ISO90001.  
Certificate number FM12587.

IBM is the registered trademark of International  
Business Machines Corporation.

AMP is a trademark of AMP Incorporated  
Molex is a trademark of Molex Incorporated  
DATA MATE is a trademark of AMP Incorporated

Other company, product and service names may be  
trademarks or service marks of others.

Produced by European SIT Lab.

© International Business Machines Corporation 1997.

This data sheet is not a substitute for the full  
production specification, which should be used when  
detailed information is required.

Product Description data represents IBM's design  
objectives and is provided for comparative purposes;  
actual results may vary based on a variety of factors.  
This product data does not constitute a warranty.  
Questions regarding IBM's warranty terms or  
methodology used to derive this data should be  
referred to your IBM OEM representative. Data  
subject to change without notice.

Date: 23rd October 1997

Distributor: