

DFHS Models S1x, S2x & S4x

IBM OEM Storage Products

High-perf 3.5" SCSI 1.12-4.51 GB (1993)

The superior performance characteristics of the DFHS family result from a combination of factors. The drives spin at 7200 rpm, have industry leading areal density, the patented PRML channel and a media data rate of 9-12 MB/sec.

APPLICATIONS

- Technical/commercial workstations
- Network servers
- Mass storage arrays
- High end personal computers

FEATURES

- 1.12/2.25/4.51GB formatted capacity (at 512 bytes/sector).
- Industry standard interface
 - 50 pin ANSI SCSI-2
 - 68 pin ANSI SCSI-3
 - single ended or differential (50/68 pin)
 - single connector attachment (SCA 80 pin)
- 9.59/12.58 MB/s media data rate. 10 bands.
- Rotational speed 7200 rpm.
- Latency 4.17ms.
- Average read seek time 7.8ms (1.12 and 2.25GB)
8.4ms (4.51GB)
- Magneto resistive heads.
- PRML data channel (partial response maximum likelihood with digital filter).
- Spindle Synchronization.
- User configurable block sizes.
- 512KB multi-segmented dual port data buffer.
- Drive supported SCSI bus terminator power.
- Industry standard mounting.
- Low command overhead.
- Read ahead caching.
- Write cache support.
- ECC on the fly.
- Predictive failure analysis.

BENEFITS

- Popular capacity points.
- Range of SCSI interfaces to suit application
 - High interface data rate
- Exceptionally high data rate across entire disk surface.
- Fast access to data.
- Industry leading areal density 543MB/sq in.
- Robust data channel for improved data integrity.
- Data Server Applications.
- Compatibility with many software systems.
- Fast data retrieval in multi-tasking environments.
- Easy integration across multiple platforms.
- Easy installation.
- Improved data throughput.
- Industry leading reliability.

ELECTRICAL CONNECTOR LOCATIONS

The electrical connectors are located as shown.

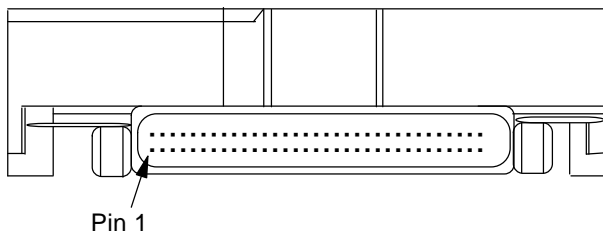

Electrical Connectors (rear view) 80 Pin SCA models

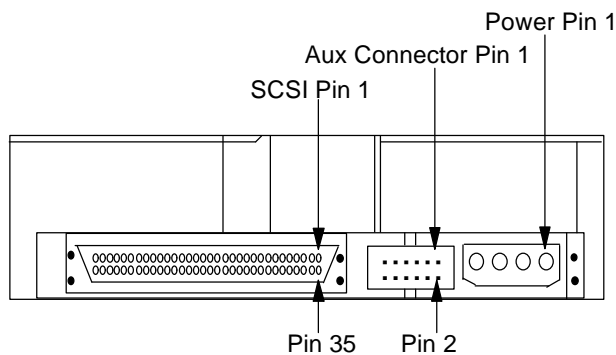

Electrical Connectors (rear view) 68 Pin models

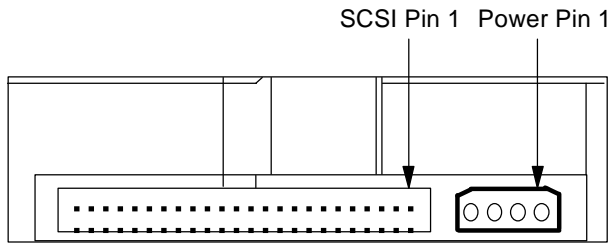

Electrical Connectors (rear view) 50 Pin models

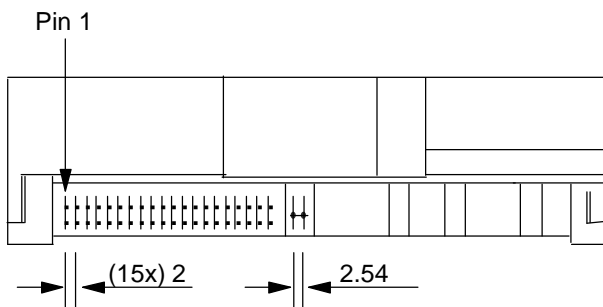

Jumper Pin Locations (front view)--all models

Note: See Electrical Interface Specifications section for power pin assignments.



WARNING: This disk drive can be damaged by Electro-Static Discharge. Please follow recommended ESD procedures before unpacking or handling the drive. Ask you IBM marketing representative for details if you need assistance.

OPTION JUMPER BLOCKS

DFHS models contain a jumper block that can be used to enable certain features and select the SCSI ID of the drive. This jumper block is referred to as the "Front" Option Jumper Block due to it's location on the drive (opposite the SCSI connector). This jumper block varies in pin definition based on interface type (50, 68, Differential, SCA).

The Option Block connector (2 x 16) used on 50 pin models is an AMP connector (PN 84156-4) having a pin spacing of 2mm.

The Option Block connector (2 x 16) used on the 68 and 80 pin model is an AMP connector (PN 84156-5) having a pin spacing of 2mm.

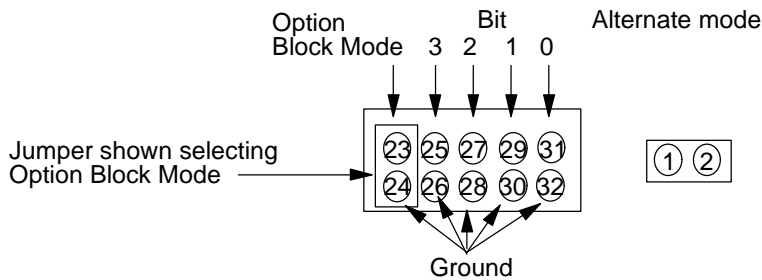
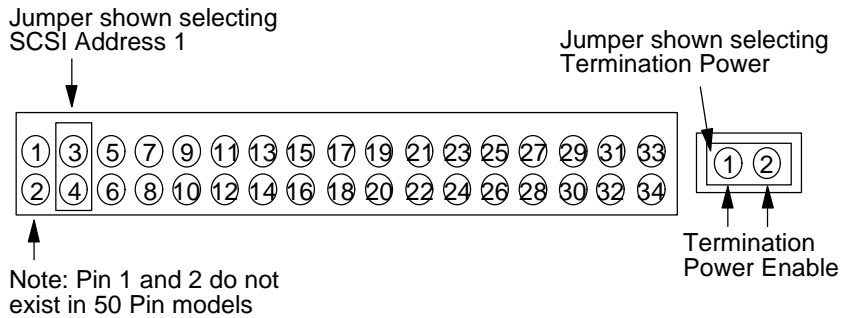

50/68 Pin Model Single-Ended

Pin

- | | |
|-------------------------------|-----------------------------------|
| 1 SCSI ID 3 68 pin only | 16 Slave Sync |
| 3 SCSI ID 2 | 17 External Activity LED |
| 5 SCSI ID 1 | 18 + 5 volt |
| 7 SCSI ID 0 | 19 Write Protect |
| 9 Blank | 21 Auto Start Delay |
| 10 Unused | 23 Option Block Mode |
| 11 Auto Start | 25 Disable T.I. Sync Negotiations |
| 13 + 5 volts | 27 Disable SCSI Parity |
| 14 Enabled Active Termination | 29 Disable Unit Attention |
| 15 MasterSync | 31 Customizing |

Note: Pins 2, 4, 6, 8, 12, 20, 22, 24, 26, 28, 30, and 32 are Ground.

50/60 Pin Model Differential

Pin	
1	SCSI ID 3 68 pin only
3	SCSI ID 2
5	SCSI ID 1
7	SCSI ID 0
9	Blank
10	Unused
11	Auto Start
13	+ 5 volts *
14	Unused*
15	MasterSync
16	Slave Sync
17	External Activity LED
18	+ 5 volt
19	Write Protect
21	Auto Start Delay
23	Option Block Mode
25	Disable T.I. Sync Negotiations
27	Disable SCSI Parity
29	Diabile Unit Attention
31	Customizing

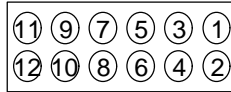
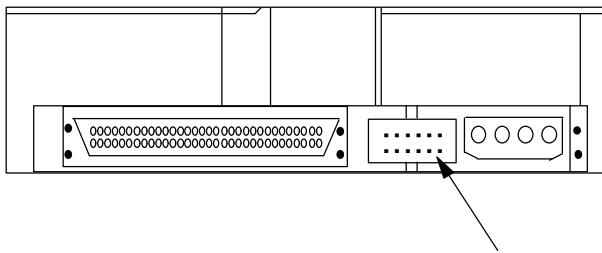

Note 1: Pin 13 is Enable Narrow Mode on 80-pin SCA and 68-pin differential models.

Note 2: Pin 14 is Ground on on 80-pin SCA and 68-pin differential models.

Note: Pins 2, 4, 6, 8, 12, 20, 22, 24, 26, 28, 30, and 32 are Ground.

68 Pin Auxiliary Connector

Pin

1	SCSI ID 0	7	SCSI ID 3
2	Unused	8	External Activity LED
3	SCSI ID 1	9	Enable Active Termination
4	Auto Spin Start	10	Ground
5	SCSI ID 2	11	+ 5 volts
6	Slave Sync	12	Write Protect

68 Pin Auxiliary Connector

The 68 pin models contain an "Auxiliary" connector that replicates some of the functions contained in the Front Option Jumper Block. The Auxiliary connector signal definition conforms to the SCSI document SFF-8009 Rev 2 with the following exceptions:

1. EXTERNAL FAULT (XTFALT-) is not supported on pin 2.
2. AUTO SPIN START was chosen as the "vendor unique" signal assignment (on pin 4).
(This signal is an input to the drive. The SCSI spec (SCSI SFF-8009) specifies this pin as an output.) This signal should be useful for those applications that want to "auto-start" the drive based on location dependent SCSI ID.
This pin should be handled in one of the following ways:
 - a. tied to ground (auto spin start enabled)
 - b. allowed to "float" (no connection)
 - c. driven with an open collector driver (> 1 mA sink capability)

Refer to auxiliary connector diagram opposite.

SCSI ID (ADDRESS) PINS

Note: In the address determination tables "off" means jumper is not in place and "on" means jumper is in place.

Address Determination--68 and 80 Pin Models

Bit3	Bit2	Bit1	Bit0	Address
off	off	off	off	0
off	off	off	on	1
off	off	on	off	2
off	off	on	on	3
off	on	off	off	4

off	on	off	on	5
off	on	on	off	6
off	on	on	on	7
on	off	off	off	8
on	off	off	on	9
on	off	on	off	10
on	off	on	on	11
on	on	off	off	12
on	on	off	on	13
on	on	on	off	14
on	on	on	on	15

Address Determination of 50 Pin Models

Bit2	Bit1	Bit0	Address
off	off	off	0
off	off	on	1
off	on	off	2
off	on	on	3
on	off	off	4
on	off	on	5
on	on	off	6
on	on	on	7

Auto Start (& Delay) Pins

The Auto Start and Auto Start Delay pins control when and how the drive can spin up and come ready. When configured for Auto-Startup, the motor spins up after power is applied without the need of a SCSI Start Unit command. For no Auto-Start, a SCSI Start Unit command is required to make the drive spin and be ready for media access operations. When in Auto-Start mode, the drive will delay its start time by a period of time multiplied by its own SCSI address.

Auto-Startup Modes selectable by Auto-Start/Delay pin Combinations

<i>Pins (50 and 68 interface pin models)</i>		<i>Drive Behavior</i>	
<i>Auto Start</i>	<i>Auto Start</i>	<i>Auto Startup</i>	<i>Delay (sec)</i>
<i>Delay</i>		<i>Mode?</i>	<i>Multiplier</i>
off	off	No	NA
off	on	Yes	0
on	off	Yes	10
on	on	Yes	4

Pins (80 interface pin models)

Drive Behavior

<i>Auto Start Delay</i>	<i>Auto Start</i>	<i>Auto Startup Mode?</i>	<i>Delay (sec) Multiplier</i>
off	off	Yes	0
off	on	No	NA
on	off	Yes	10
on	on	No	NA

External Activity (LED) Pins

The LED pins can be used to drive an external Light Emitting Diode. Please refer to the LED pin section of the DFHS Interface Specification for a detailed functional description of this pin.

Up to 33 mA (plus or minus 5%) of TTL level LED drive capability is provided. Current limiting for the LED is provided on the electronics card. The LED Anode may be tied to the +5V source provided on pin 18 of the Front Option Jumper Block, pin 11 of the Auxiliary connector on the 68 pin Unitized connector or the 5V power source on the 80 pin SCA model. The LED Cathode is then connected to the EXTERNAL ACTIVITY Pin to complete the circuit.

Note: this set of pins can be used to drive an LED located in a bezel connected to the front end of the drive or to an external LED in systems where the front of the drive cannot be easily seen.

Note: 68 pin and 80 pin SCA SCSI models have two sets of pins, a set on the front and a set on the back, that are connected to the same LED driver circuit. The combined drive capability is stated above.

Write Protect Pin

If the Write Protect pin is jumpered to ground, the drive will prohibit SCSI commands that alter the customer data area portion of the media from being performed. The state of this pin is monitored on a per command basis. See the DFMS interface specification for functional details.

Option Block Mode Pin

The Option Block Mode pin is used to modify the function of the Front Option Jumper Block. When the Option Block Mode Pin is not grounded the pin function of the Front Option Jumper Block will be as defined by the upper portion of the referenced figures. When the Option Block Mode Pin is grounded the pins (25, 27, 29, 31) will be redefined to control what is referred to as "Alternate Mode."

"Alternate Mode" allows tailoring of SCSI options such as "boot up" characteristics and other operational features on a per customer basis.

Please contact your IBM Customer Representative for functional details on the customization of function allowed by this mode.

The state of these pins immediately after power is applied to the drive will determine their function.

Disable T.I. Sync Negotiation Pin

If a Disable Target Initiated Synchronous Negotiation pin is grounded then an Initiator is required to start a negotiation handshake if Synchronous and/or "Wide" (Double Byte) SCSI transfers are desired. Please refer to the DFHS Interface Specification for more details on this feature.

Disable SCSI Parity Pin

Grounding this pin will disable SCSI Parity checking.

Disable Unit Attention Pin

Grounding this pin will disable the drive from building Unit Attention Sense information for commands immediately following a Power On Reset (POR) or SCSI Bus Reset. Any pending Unit Attention conditions will also be cleared at POR or SCSI Reset times.

Customizing Pin

The customizing pin is currently reserved for future use.

Enable Narrow Mode

Jumpering pin 14 to pin 13 will cause the 68 pin Differential or the 80 pin SCA to operate in a Single Byte mode. The drive will not negotiate for "Wide" (Double Byte) operation. The drive will terminate the unused upper byte and upper byte parity on the SCSI Bus.

Enable Active Termination

Upon request, Single Ended 50 and 68 pin models are available with on card SCSI bus Active terminators. (Please contact your IBM Customer Representative for the appropriate card PN).

For those cards having the Active Termination feature, this function can be enabled by installing a jumper between pins 13 and 14 of the Front Option Jumper Block or connecting pins 9 and 11 of the Auxiliary Connector on 68 SCSI pin models.

DATA ORGANIZATION

Note: The recording band located nearest the disk outer diameter (OD) is referenced to as "Notch No 1." While the recording band located nearest the inner diameter (ID) is called "Notch No 10." "Average" values are weighted with respect to the number of LBAs per notch when the drive is formatted with 512 byte blocks.

Data Transfer Rates

Notch	No 1	No 10	Average
Buffer to/from media	12.58	9.59	12.07
	MB/s (instantaneous)		
Host to/from buffer	up to 20.0 MB/s		
	(synchronous) (sustained)		
Data buffer size (bytes)	512K		
Rotational speed (RPM)	7202.7		
Average latency (milliseconds)	4.17		
Track density (TPI)	4352		
	Min	Max	
Recording density (BPI)	96,567	124,970	
Areal density (Megabits/sq in)	420.3	543.9	
Model Numbers	S4x	S2x	S1x
Disks	8	4	2
User data heads (trk/cyl)	16	8	4
Seek times (in milliseconds)			
Single Cylinder (Read)	0.6	0.6	0.6
(Write)	2.5	2.5	2.5
Average (weighted (Read)	8.4	7.8	7.8
(Write)	9.9	9.3	9.3
Full stroke (Read)	16.5	16.5	16.5
(Write)	19.0	19.0	19.0

Notes: Times are typical for a drive population under nominal voltages and casting temperature 25 degrees C. Weighted seeks are seeks to the cylinders of random logical block addresses (LBAs).

Total Cylinders (tcyl) & User Cylinders (ucyl)

	<i>All models</i>	<i>S4x</i>	<i>S2x</i>	<i>S1x</i>
	tcyl	ucyl	ucyl	ucyl
Notch No 1	1893	1879	1877	1872
Notch No 2	956	955	955	955
Notch No 3	49	48	48	48
Notch No 4	310	309	309	309
Notch No 5	349	348	348	348
Notch No 6	116	115	115	115
Notch No 7	214	213	213	213
Notch No 8	190	189	189	189
Notch No 9	131	130	130	130
Notch No 10	208	206	206	206
Sum of all Notches	4416	4392	4390	4385

Spare Sectors/cylinder

S4x S2x S1x

Notch No 1	40	20	10
Notch No 2	40	20	10
Notch No 3	38	19	10
Notch No 4	37	19	9
Notch No 5	36	18	9
Notch No 6	34	17	9
Notch No 7	33	17	8
Notch No 8	32	16	8
Notch No 9	31	16	8
Notch No 10	30	15	7

Last cylinder extra spares

60	30	14
----	----	----

User bytes/sector

256-744 (even number of bytes only)

Sectors/logical block

1-8

The lowest sectors/lba that satisfies the following rules is used:

1. Block Length is evenly divisible by a number 2-8.
2. Quotient of previous equation is evenly divisible by 2.
3. Quotient must be greater than or equal to 256 and less than or equal to 744.

User bytes/logical block

256-5952

Gross sectors per track for several block lengths

<i>User bytes/ logical block</i>	<i>Notch Number</i>									
	1	2	3	4	5	6	7	8	9	10
256	216	216	216	202	195	180	180	180	180	162
512	135	135	130	126	120	115	112	108	105	100
520	128	128	128	123	115	112	108	105	102	99
522	128	128	128	122	115	112	108	105	102	90
524	128	128	128	120	115	112	108	105	102	90
528	128	128	126	120	112	112	108	105	101	90
688	102	102	102	98	90	90	90	90	81	78
744	96	96	96	90	90	90	81	78	77	73

User capacity for several block lengths

S1x Models

<i>User bytes/ logical block</i>	<i>formatted capacity (bytes)</i>	<i>logical blocks/ drive</i>
256	912,135,680	3,563,030
512	1,126,337,536	2,199,878

520	1,092,119,600	2,100,230
522	1,091,803,716	2,091,578
524	1,094,691,544	2,089,106
528	1,100,365,728	2,084,026
688	1,149,310,880	1,670,510
744	1,167,099,408	1,568,682

S2x Models

<i>User bytes/ ,logical block</i>	<i>formatted capacity (bytes)</i>	<i>logical blocks/ drive</i>
256	1,826,312,448	7,134,033
512	2,255,098,368	4,404,489
520	2,186,554,760	4,204,913
522	2,185,931,898	4,187,609
524	2,191,716,460	4,182,665
528	2,203,082,640	4,172,505
688	2,300,969,904	3,344,433
744	2,336,559,528	3,140,537

S4x Models

<i>User bytes/ logical block</i>	<i>formatted capacity (bytes)</i>	<i>logical blocks/ drive</i>
256	3,654,540,800	14,275,550
512	4,512,701,440	8,813,870
520	4,375,536,880	8,414,494
522	4,374,300,492	8,379,886
524	4,385,878,952	8,369,998
528	4,408,629,984	8,349,678
688	4,604,578,976	6,692,702
744	4,675,830,192	6,284,718

MODE SELECT OPTIONS

Certain parameters are alterable using the SCSI "Mode Select" command. This allows certain drive characteristics to be modified to optimize performance on a particular system. Refer to the DFHS SCSI Functional Specification for a detailed definition of Mode Select parameters.

DC POWER REQUIREMENT LIMITS

The following voltage specifications apply at the drive power connector. There are no special power on/off sequencing requirements.

+12 Volt Supply

- +/- 5.0% (during run)
- +5.0% / -7.0% (during spin-up)

+5 Volt Supply

- +/- 5.0% (during run and spin-up)

S1x and S2x Power Supply Current +5VDC

	Notes	Population Mean
Idle average		.690 Amps (note 1)
R/W average		.98 Amps
R/W pulse	Base-to-peak	.28 Amps

S4x Power Supply Current +5VDC

Idle average		.720 Amps
R/W average		1.01 Amps
R/W pulse	Base-to-peak	.33 Amps

S1x Power Supply Current +12VDC

Idle average		.3 Amps
Seek average	1 op/sec	.0027 amps
Seek peak		1.2 Amps (note 2)
Spin-up	1.5 sec max	1.5 Amps (note 3)

S2x Power Supply Current +12VDC

Idle average		0.43 Amps
Seek average	1 op/sec	0.003 Amps
Seek peak		1.2 Amps (note 2)
Spin-up	1.5 sec max	2.7 Amps (note 3)

S4x Power Supply Current +12VDC

Idle average		0.84 Amps
Seek average	1 op/sec	0.004 Amps
Seek peak		1.2 Amps (note 2)
Spin-up	1.5 sec max	2.7 Amps (note 3)

Notes on typical current draws:

1. 5 Volt current is given with termination power provided by the using system.
2. The idle average and seek peak should be added together to determine the total 12 volt peak current.
3. The current at start is the total 12 volt current required (ie, the motor start current, module current and voice coil retract current).

Externally generated ripple

(as seen at drive power connector)

<i>Voltage</i>	<i>Maximum</i>	<i>Notes</i>
+5VDC	150mV peak-to-peak	0-20MHz
+12VDC	150mV peak-to-peak	0-20MHz

During drive start up and seeking, 12 volt ripple is generated by the drive (referred to as dynamic loading). If several drives have their power daisy chained together then the power supply ripple plus other drive's dynamic loading must remain within the regulation tolerance window of $\pm 5\%$. A common drive supply with separate power leads to each drive is a more desirable method of power distribution.

MODELS

The DFHS disk drive is available in the following capacities:

DFHS-31080	1.0GB
DFHS-32160	2.0GB
DFHS-34320	4.0GB

The DFHS capacities vary as a function of model and user block size. The emerging Industry Standard Capacity points are multiples of 1.08GB (ie, 1.08/2.16/4.32) at a block size of 512 bytes. This and future products will plan to provide capacities that are consistent with this standard.

Users who choose to make full use of the DFHS drive capacity above the standard capacity points may not find equivalent capacity breakpoints in future products.

Note:

"SEF" stands for Single Ended Fast
"SEF/W" stands for Single Ended Fast/Wide
"DF/W" stands for Differential Fast/Wide

Notes:

- 50 pin SCSI connector models offer an 8 bit SCSI bus using the SCSI "A" connector.
- 68 pin SCSI connector offers an 8/16 bit SCSI bus using the SCSI "P" connector which supports Wide data transfers.
- 80 pin SCSI connector models offer an 8/16 bit SCSI bus using the SCA connector.
- All models support Fast SCSI data transfers.

OPERATING ENVIRONMENT

The drive operates with its performance limits when the following environment is maintained. Product life calculations are based on the nominal environment for a typical application.

Humidity:

Operating	5% to 90% noncondensing
Storage	5% to 95% noncondensing
Shipping	5% to 100%

(applies at a packaged level)

Wet Bulb Temperature:

Operating & Storage	80 degrees F (26.7 degrees C) maximum
Shipping	85 degrees F (29.4 degrees C) maximum

Elevation:

Operating	-1000 to 10,000 feet (-304 to 3048 meters)
Shipping/Storage	-1000 to 40,000 feet (-304 to 12,192 meters)

Temperature:

Operating ambient	41 to 131 degrees F (5 to 55 degrees C)
Operating casting temperature	41 to 158 degrees F (5 to 60 degrees C)
Shipping	-40 to 149 degrees F (-40 to 65 degrees C)
Storage	34 to 149 degrees F (1.1 to 65 degrees C)

Temperature Gradient:

Operating	36 degrees F (20 degrees C) per hour
Shipping/Storage	Below condensation

These temperature limits are extremely important and must not be exceeded at the worst case drive and system operating conditions with the drive randomly seeking, reading, and writing.

HOT PLUG/UNPLUG SUPPORT

Power supply and SCSI bus hot plug and unplug is allowed. There is no special sequence required for connecting 5 volt, 12 volt, or ground. During a hot plug-in event the drive being plugged will draw a large amount of current at the instant of plug-in. This current spike is due to charging the bypass capacitors on the drive. This current pulse may cause the power supply to go out of regulation. If this supply is shared by other drives then a low voltage is initiated on those drives. Therefore the recommendation for hot plug for each drive. Never daisy chain the power leads if hot plug should be minimized to prevent wear on the power

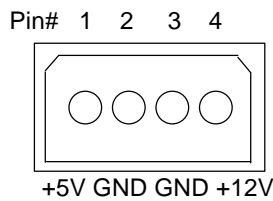

us may cause glitches on the bus. To minimize the chance of glitching, it is recommended to plug in the SCSI bus before the power is applied.

During hot plugging, the supplies must not go over the upper voltage limit. This means that proper ESD protection must be used during the plugging event.

ELECTRICAL INTERFACE SPECIFICATIONS

Power Connector

The DC power connector used on all models (50, 68, and 80 pin SCA) are an integral portion of the 50/68 pin SCSI "Unitized" Connectors or the 80 pin "Single Connector Attachment" (SCA) Connector.

Power connector pin assignments

SCSI Bus Connector

DFHS has different model types that support 50 or 68 pin SCSI connectors in either single-ended or differential driver/receiver configurations. Also supported is the 80 pin SCA in a single-ended driver/receiver configuration.

50 Pin Signal Connector

50 pin models use an AMP PN 84160-1 connector. The connector is compatible with the ANSI SCSI "A" connector specifications. It is limited to 8 bit data transfers only.

68 Pin Signal Connector

58 pin models use an AMP connector (PN 786963-1) that is compatible with the ANSI SCSI "P" connector specifications. It can transfer data in both 8 bit (narrow) and 16 bit (wide) modes.

Note: That the "P" connector is not mechanically compatible with the 50-pin "A" connector as defined in the ANSI SCSI-2 standard. Therefore system cables used with 50 pin products cannot be plugged directly into 68 pin models. Despite the difference in connector, the differential 68 pin models are electrically compatible with differential 50 pin models and other 50 pin differential SCSI products and therefore can coexist on the same bus. In order to do so, the differences in connector types would need to be accounted for in the cable. The same can be said for connecting 68 and 50 pin single-ended models to the same bus. Differential and single-ended models do not work connected to the same bus.

80 Pin (Single Connector Attachment) Connector

80 pin SCA models use a Molex connector (PN 87091-0001) that is compatible with the specification of: "Single Connector Attachment for Small SCSI Disk Drives." It can transfer data in both 8 bit (Narrow) and 16 bit (wide) modes.

Note: That the "SCA" connector is not mechanically compatible with the 50 pin "A" connector or the 68 pin "P" connector as defined in the ANSI SCSI standard. This connector is intended for direct backplane attachment and is not intended to be cable attached to the bus.

SCSI Bus Cable

Single-ended models permit cable lengths of up to 6 meters (19.68 feet). It should be noted however that users who plan to use "Fast" data transfers with single-ended models should follow all of the ANSI SCSI guidelines for single-ended "Fast" operations. This may include a cable length of less than 6 meters.

SCA connector models are not designed for direct cable attachment due to the combination of power and SCSI bus signals. "Fast" data transfers with SCA models should follow all of the ANSI SCSI guidelines for single-ended "Fast" operations.

Differential models permit cable lengths of up to 25 meters (82.02 feet). Cables must meet the requirements for differential cables as set forth in the ANSI SCSI-2 standard under "Cable Requirements--Differential Cable."

The ANSI SCSI standard states that any stub from main cable must not exceed 0.1 meters for single-ended cables and 0.2 meters for differential cables. <O| DFHS |O> has a maximum internal stub length of 0.05 meters on all "single-ended" SCSI signals, and 0.1 meters on all "differential" SCSI signals. To remain compliant with the standard, the SCSI bus cable must

models can source up to 1.5 Amps of current at 5.0 Volts (plus/minus 5%) for termination power.

SCSI Bus Termination Power Short Circuit Protection

The ANSI SCSI-2 specification recommends for devices that optionally supply TERMPWR, to include current limited protection for accidental short circuits. It also recommends that the maximum current available for TERMPWR should not exceed 5 Amps, UL has a different requirement that they call 8 Amp rule. This rule states that when a power source leaves an enclosure (like SCSI TERMPWR in the SCSI cable), it must trip 8 Amps of current within 1 minute.

The drive limits current to 5.0 amps through the use of a permanent fuse mounted on the electronics card. Systems may also provide short circuit protection for drive supplied TERMPWR by limiting the current of the 5v power it supplies to the drive.

SCSI BUS NOISE REDUCTION RECOMMENDATIONS

The SCSI committee has spent a large amount of resource looking into what needs to be done

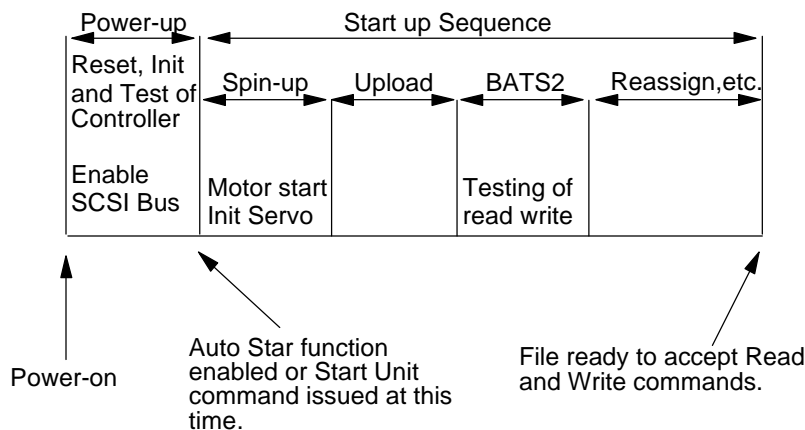

to assure SCSI devices will work as specified in the SCSI-2 standard. As a result of this, the committee is recommending the following approach.

- Use regulated 110 ohm terminator
- Use AWG 28 polyoelfin shielded cables
- Make sure data and parity are on the outer ring of the cable and that REQ and ACK are in the core of the cable.

START AND STOP TIMES

Time *Nominal* *Maximum*

Models	S1x	S2x	S4x	S1x	S2x	S4x
Power Up	1.5	1.5	1.5	2.0	2.0	2.0
Start-up	12.4	17.6	16.5	1 min	1 min	1min
Spin-up	8.2	13.2	11.7	30.8	30.8	32.1
Stop Time	6.0	9.0	8.0	12.0	12.0	12.0

Note: Seconds unless stated.

Note: BATS is the abbreviation for Basic Assurance Tests. Start-up sequence spins up the spindle motor, uploads code, performs BATS2 (verifies read/write hardware), resumes "Reassign in Progress" operations, and more. For more information on the start-up sequence, refer to the <O| DFHS |O> Interface Specification.

Note: If a RESET is issued before the drive comes ready the power on sequence will start again. In all other cases when a RESET is issued the present state of the motor is not altered.

VIBRATION AND SHOCK

Operating/Nonoperating Vibration

Due to the complexity of this subject we recommend that users contact the Distributor to discuss how to perform the required measurements if they believe this to be an area which requires evaluation.

Operating Shock

The drive will continue to operate, at the stated "Performance" when subjected to a 5G half sine wave shock pulse of 11 milliseconds duration.

No permanent damage will occur to the drive when subjected to a 10G half sine wave shock pulse of 11 milliseconds duration.

The shock pulses are applied in either direction in each of three mutually perpendicular axes, one axis at a time.

Nonoperating Shock

No damage will occur if the unpackaged drive is not subjected to a square wave shock greater than a "faired" value of 35 Gs applied for a period of 20 milliseconds, in one direction at a time.

Additionally, no damage will occur if the unpackaged drive is subjected to an 11 millisecond half-sine wave shock of not greater than 60 Gs applied to all three axes, one axis at a time.

MECHANICAL SPECIFICATIONS

This section details the mechanical specifications of the IBM OEM DFHS disk drive. (All versions)

Weight

S1x, S2x models

Approximately 1.0 pounds (0.46 kilograms)

S4x model

Approximately 1.8 pounds (0.82 kilograms)

Dimensions

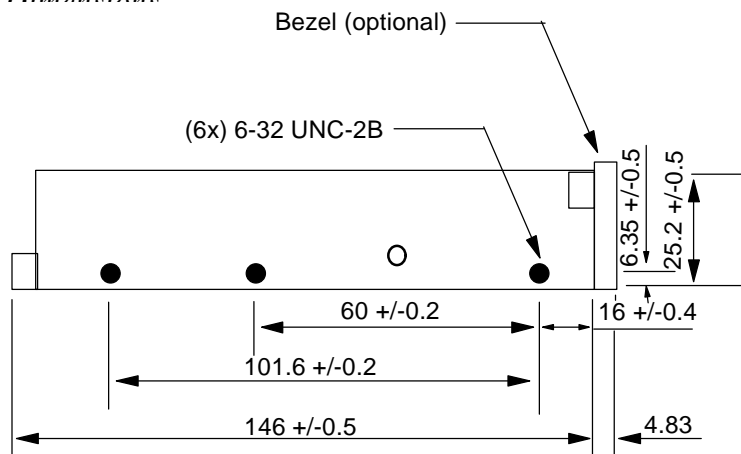

surface except for a 10mm
1 shows the 2mm clearance
clearance of 6mm be provided

n by more than 2 millimeters

during a nonoperating shock.

Mounting

The drive can be mounted with any surface facing down.

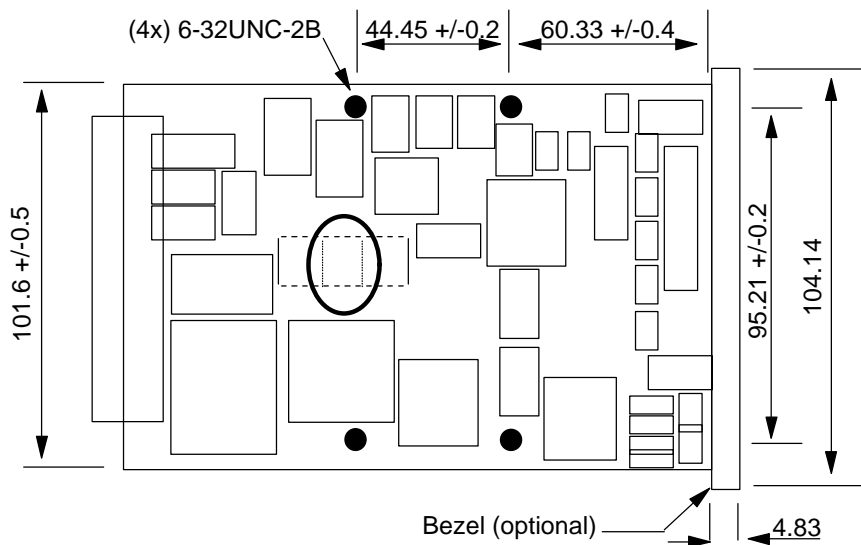

The drive has both side and bottom mounting holes. Refer to diagrams below for the location of these mounting holes for each configuration.

The maximum allowable penetration of the mounting screws is 3.8mm.

The torque applied to the mounting screws must be 0.8 Newton meters plus/minus 0.1 Newton meters

Location of side mounting holes

Bottom View

Grounding Requirements of the disk enclosure

The disk enclosure is at Power Supply ground potential. It is allowable for the user mounting scheme to common the Disk Enclosure to Frame Ground potential or to leave it isolated from

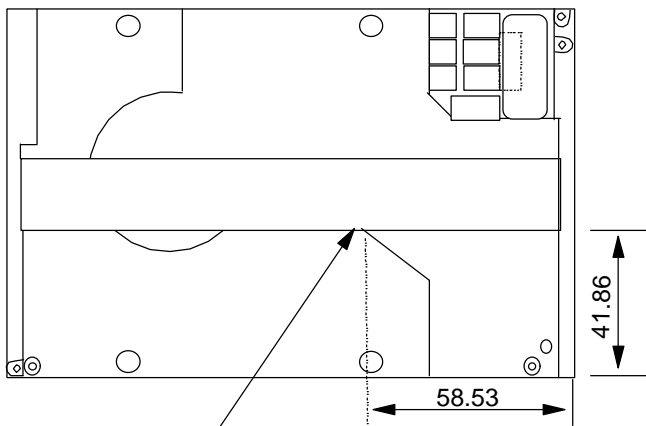

Disk Enclosure
Top

Frame Ground.

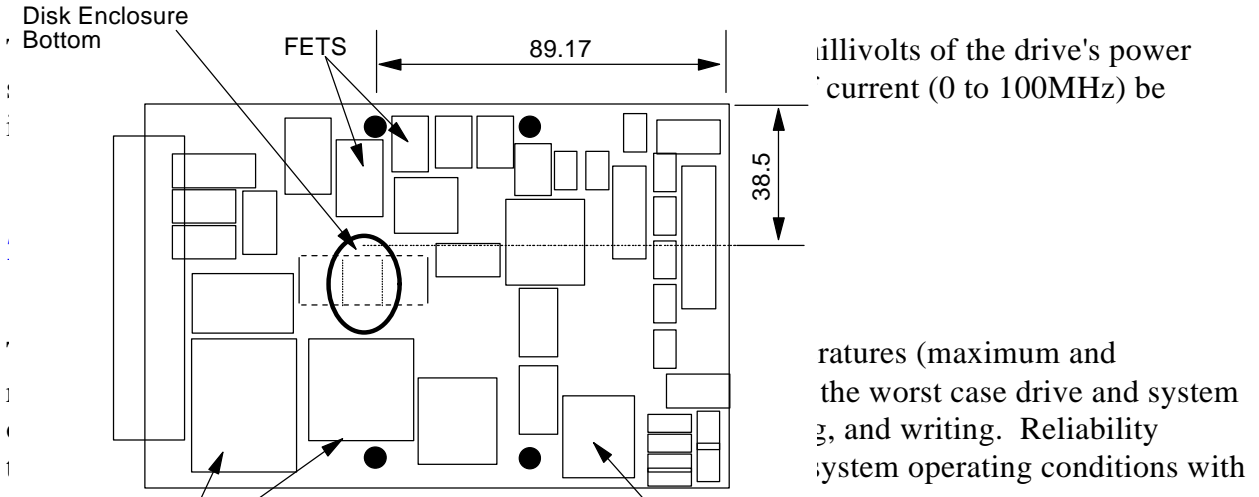

WD COMBO Microprocessor		
Disk Enclosure Top	158 F (70 C)	131 F (55 C)
Disk Enclosure Bottom	158 F (70 C)	131 F (55 C)
PRDF Module	203 F (95 C)	176 F (80 C)
WD COMBO Module	185 F (86 C)	167 F (75 C)
Microprocessor Module	194 F (90 C)	167 F (75 C)
VCM FET	194 F (90 C)	167 F (75 C)
SMP FET	194 F (90 C)	167 F (75 C)

Top view

Bottom view

- In the nonsync mode, the drive will receive the -SLAVE SYNC signal, but it is not used by the drive.

SPINDLE SYNCHRONIZATION CONTROL LINES

Spindle Synchronization Functional Modes

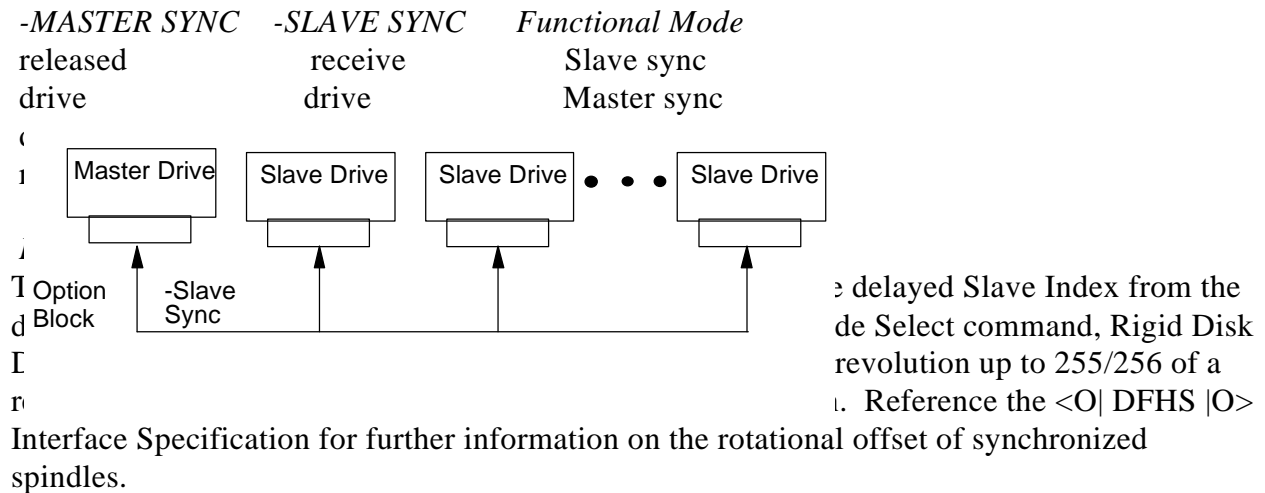

Synchronized Time

The SCSI Mode Select command is used to select the Spindle Sync mode. It could take up to 3.0 seconds (1.5 sec nominally) to synchronize the Slave drive to the Master drive. While the Slave drive is synchronizing to the Master, it will not be able to read and write data. Once synchronized, the drive will maintain plus/minus 20 usec synchronization tolerance.

Spindle Synchronization Bus

The spindle synchronization Bus consists of the two signal lines, MASTER SYNC and -SLAVE SYNC. One potential configuration of this bus for drives that are to be used in a synchronized mode is shown in the following figure. This example required the -SLAVE SYNC lines to be daisy chained together.

Termination

Bus termination of the -MASTER SYNC and -SLAVE SYNC signals is internal to the drive. These two signals each have a 2000 ohm pullup to the +5 volt supply. A maximum of 16 drives can have their -MASTER SYNC or -SLAVE SYNC lines daisy chained together. Violating this could damage the Master drive line driver on the MASTER SYNC and/or -SLAVE SYNC line.

It is the using system's responsibility to provide the cable to connect to the -SLAVE SYNC lines, and the -MASTER SYNC lines where needed, of the synchronized drives.

Bus Characteristics

- maximum Bus length is 6 meters
- 2 micro-second negative active pulse (when sourced to drive)
- minimum of 1 micro-second negative active pulse when externally sourced
- 0.8 volts = valid low input
- 2.2 volts = valid high input
- 0.4 volts = low output
- Vcc volts = high output
- 60 milli-amps = maximum output low level sink current

The driver used for these two signal lines is a tri-state buffer.

SLAVE SYNC Input Timing Requirements

If the input to -SLAVE SYNC is supplied by an external source other than a <O| DFHS |O> drive, the period of the input signal must be 8.333 msec with a tolerance of +/- .025%.

REGISTERS

	<i>Address</i>	<i>Input Register</i>	<i>Output Registers</i>
	1F0h	Data	Data
	1F1h	Error	Features
	1F2h	Sector Count	Sector Count
	1F3h	Sector Number	Sector Number
		*LBA bits 0-7	*LBA bits 0-7
	1F4h	Cylinder Low	Cylinder Low
		*LBA bits 8-15	*LBA bits 8-15
1F5h	Cylinder High	Cylinder High	
	* LBA bits 16-23	*LBA bits	
1F6h	Drive/Head	Drive/Head	
	*LBA bits 24-27	*LBA bits 24-27	
1F7h	Status	Command	
3F6h	Alternate Status	Device Control	
3F7h	Drive Address	Not used	

The host uses the register interface to communicate to and from the drive. The registers are accessed through the host port addresses shown.

The host should not read or write any registers when the Status Register BSY bit = 1.

Note: * Meaning of Register contents when LBA addressing mode used.

PACKAGING: The drive must be protected against Electro-Static Discharge especially when being handled. The safest way to avoid damage is to put the drive in an anti-static bag before ESD wrist straps etc are removed.

Drives should only be shipped in approved containers, severe damage can be caused to the drive if the packaging does not adequately protect against the shock levels induced when a box is dropped. Consult your IBM marketing representative if you do not have an approved shipping container.

ELECTROMAGNETIC COMPATABILITY

The Drive meets the following EMC requirements when installed in the user system and exercised with a random accessing routine at maximum data rate:

United States Federal Communication Commission (FCC) Rules and Regulations Part 15, Subject J -Computer Devices "Class B Limits"

Europe Economics Community (ECC) directive #76/889 related to the control of radio frequency interference and the Verband Deutscher Elektro-techniker (VDE) requirements of Germany (GOP).

AMP is a trade mark of
AMP Incorporation.

Molex is a trade mark of
Molex Incorporation.

DATA MATE is a trade mark of
AMP Incorporated.

IBM OEM Europe
PO Box 6

Langstone Road
Havant
Hampshire
PO 9 ISA
United Kingdom
Telephone: (44) 1 705 486363

This data sheet is not a substitute for the full product specification, which should be used when detailed information is required.

Product Description data represents IBM's design objectives and is provided for comparative purposes; actual results may vary based on a variety of factors. This product data does not constitute a warranty. Questions regarding IBM's warranty terms or methodology used to derive this data should be referred to your IBM OEM representative. Data subject to change without notice.