

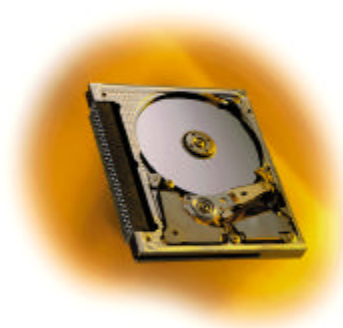

Product summary

IBM Microdrive™

CF+ Type II



Models: DMDM-10340
DMDM-10170

Introduction

The IBM Microdrive comes in capacities of 340 MB and 170 MB. Developed to meet the needs of handheld systems and devices, it is one of the highest capacity hard disk drives available in a one-inch diameter.

Applications

- Digital photography cameras
- Handheld PCs
- Personal Data Attendants
- Digital video cameras

Features	Benefits
<ul style="list-style-type: none"> • Formatted capacities of 340 MB and 170 MB at 512 bytes per sector 	<ul style="list-style-type: none"> • High capacity in compact 1-inch diameter form factor
<ul style="list-style-type: none"> • CF+ Type II Card compliance 	<ul style="list-style-type: none"> • Popular interface with a wide array of applications
<ul style="list-style-type: none"> • Shock 1000 G (1 ms) non-operational • Shock 150 G (2 ms) operational 	<ul style="list-style-type: none"> • Robust design for portable computing applications
<ul style="list-style-type: none"> • 30.1 - 45.2 Mbits/s media data transfer rate • Rotational speed - 4500 RPM 	<ul style="list-style-type: none"> • Excellent data rate across disk surface
<ul style="list-style-type: none"> • Average seek time 15 ms (read) • Average latency 6.7 ms 	<ul style="list-style-type: none"> • Fast access to data
<ul style="list-style-type: none"> • No-ID sector formatting • PRML data channel 	<ul style="list-style-type: none"> • More data stored per track, increased sustained data transfer rate
<ul style="list-style-type: none"> • 128 KB buffer for read and write • On The Fly correction 	<ul style="list-style-type: none"> • Fast access to data and improved throughput • High reliability
<ul style="list-style-type: none"> • Load/Unload heads 	<ul style="list-style-type: none"> • Increased durability during power save modes and non-operation
<ul style="list-style-type: none"> • Giant Magnetoresistive heads 	<ul style="list-style-type: none"> • High areal density, low component count
<ul style="list-style-type: none"> • Adaptive power save control 	<ul style="list-style-type: none"> • Low power for battery powered applications (0.65 watt at idle state)

Data organization (logical)

DMDM-	10170	10340
Number of logical heads	16	16
Logical sectors/track	63	63
Number of logical cylinders	344	695
Logical sector size	512	512
Total customer usable data sectors	346,752	701,569
Total customer usable data bytes	177,537,024	358,686,720



ATTENTION: The drive must be protected against electrostatic discharge (ESD) especially when being handled. The safest way to avoid damage is to put the drive in an anti-static bag before ESD wrist straps are removed.

Drives should only be shipped in approved containers. Severe damage can be caused to the drive if the packaging does not adequately protect against the shock levels induced when a box is dropped. Consult your IBM representative if you do not have an approved shipping container.

Interface connector

The interface connector of the IBM Microdrive complies with CompactFlash Specification Revision 1.3.

DC power requirements

The DMDM-10340/10170 supports both 3.3 V and 5 V power supply, and the voltage is automatically detected by the drive

Power supply	+3.3V power supply case	+5V power supply case	Notes
Nominal supply	+3.3 volts	+5 volt	1
Power supply ripple (0 - 20Mhz)	70 mv p-p max	100 mv p-p max	2
Tolerance	±5%	±5%	3
Supply current	Population mean (nominal condition)	Population mean (nominal condition)	
Idle average	230 mA RMS typical (0.73W)	260 mA RMS typical (1.2W)	4
Read average	280 mA RMS typical (0.92W)	320 mA RMS typical (1.6W)	5
Write average	300 mA RMS typical (1.1W)	330 mA RMS typical (1.7W)	
Seek average	270 mA RMS typical (0.90W)	310 mA RMS typical (1.6W)	6
Standby	65 mA RMS typical (0.21W)	80 mA RMS typical (0.4W)	
Start up (maximum RMS in 10 ms windows)	260 mA RMS typical (0.86W)	280 mA RMS typical (1.4W)	
Supply rise time	0 - 100 ms	0 - 100 ms	

Notes

1. Current limiter less than 10A is recommended for safety in user application.
2. The maximum fixed disk ripple is measured at 5V input of the drive.
3. The disk drive should not incur damage for an over voltage condition of + 25% (maximum duration of 20 ms) on the 5 volt nominal supply.
4. The idle current is specified at an inner track.
5. The read/write current is specified based on three operations of 63 sector read/write per 100 ms.
6. The seek average current is specified based on three operations per 100 ms.

Command descriptions

The following commands are supported by the drive:

Commands	Code (Hex)	Class
Check power mode	E5 or 98	1
Execute device diagnostic	90	1
Erase sectors	C0h	1
Format track	50	2
Identify drive	EC	1
Idle	E3 or 97	1
Idle immediate	E1 or 95	1
Initialize device parameters	91	1
Read buffer	E4	1
Read long sector	22 or 23	1
Read multiple	C4	1
Read sector(s)	20 or 21	1
Read sectors (no retry)	21	1
Read verify sector(s))	40 or 41	1
Recalibrate	1X	1
Request sense	3	1
Seek	7X	1
Set features	EF	1
Set multiple mode	C6	1
Set Sleep Mode	E6 or 99	1
Standby	E2 or 96	3
Standby immediate	E0 or 94	3
Translate Sector	0	1
Wear level/ Freeze lock	F5	1
Write buffer	E8	2
Write long sector (retry)	32 or 33	2
Write multiple	C5	3
Write multiple w/o erase	CD	3
Write sector(s)	30 or 31	2
Write sector(s) w/o erase	38	2
Write verify	3C	3

Class

Class 1. Upon receipt of a Class 1 command the card sets BSY within 400 ns.

Class 2. Upon receipt of a Class 2 command the card sets BSY within 400 ns, sets up the sector buffer for a write operation, sets DRQ within 700 us, and clears BSY within 400 ns of setting DRQ.

Class 3. Upon receipt of a Class 3 command the card sets BSY within 400 ns, sets up the sector buffer for a write operation, sets DRQ within 20 ms (assuming no reassignments), and clears BSY within 400 ns of setting DRQ.

Signal definition

For signal definition, refer to CompactFlash Specification version 1.3.

Load/Unload heads

When used properly, the Load/Unload mechanism is designed to allow 300,000 cycles of starts and stops. The heads are unloaded by invoking one of the following commands:

- SOFT RESET
- STANDBY
- STANDBY IMMEDIATE

The Load/Unload mechanism is also invoked as one of the idle modes. After a short period of inactivity the Adaptive Battery Life Extender power management will unload the heads to conserve energy. When the heads are

unloaded, they rest in a small detent. To prevent the heads from being thrown off the ramp during angular acceleration, a bi-directional, normally open, mechanical latch engages with the actuator to keep it from turning in the head loading direction. This action causes a “rattle” sound to be heard which can be mistaken for loose parts.

Adaptive Battery Life Extender-2

The Adaptive Battery Life Extender-2 (ABLE-2) provides power saving without performance degradation. ABLE-2 technology automatically determines the correct time to start removing power from the drive electronics.

Most software and operating systems make use of a disk drive in bursts. The IBM Microdrive monitors the commands which are sent from the host to detect patterns which indicate that a command sequence is finished by putting the drive into low overall power consumption and longer battery life with no loss in performance. If the host system changes the number or frequency of commands which it sends then the disk drive will adapt automatically to this new pattern.

This feature has three idle modes: Performance idle mode, Active idle mode, and Low Power idle mode.

Operating modes

To provide the greatest flexibility of operation with optimum performance and power consumption, the drive has a number of operating modes. These are defined below.

Spin Up

Start up time period from spindle stop or power down.

Seek

Seek operation mode

Write

Write operation mode

Read

Read operation mode

Performance idle

During Performance idle, the drive is spinning but is not performing a command. It can respond immediately if a new command is received. The transition from active mode to Performance idle mode is controlled by the arrival and completion of commands from the host system.

Low Power idle

During Low Power idle, the drive is spinning but is not performing a command. The drive has determined that the previous command sequence (group of associated commands) is complete. Some of the drive electronics have been powered down but it can still respond to a new command within about 300 ms. The transition from performance idle to low power idle is controlled by IBM's patented Adaptive Battery Life Extender technology.

Standby

While in Standby mode the drive is not spinning and is not performing a command. All electronics except for the command interface are

turned off. The transition to standby is controlled by a programmable timer which is set by the host system using standard ATA commands. After receiving a new command, the drive will start spinning again and perform the command within 2 to 3 seconds (typically).

Sleep

While in Sleep mode, the drive is not spinning and is not performing commands. All of the electronics are turned off. The transition to Sleep mode is controlled by a command which is sent by the host system. The transition from Sleep to another mode can only be triggered by a reset.

Operating environment

The drive operates within its performance limits when the following environment is maintained. Product life calculations are based on the nominal environment for a typical application.

Relative humidity

(non-condensing)

Operating	8% to 90%
Non-operating	5% to 95%

Wet bulb temperature

(non-condensing maximum)

Operating	29.4°C
Non-operating	40°C

Elevation

Operating altitude	-300 to 3,000 m (10 Kft)
Non-operating altitude	-300 to 12,000 m (40 Kft)

Temperature

Operating	5 to 55°C
Non-operating	-40 to 65°C
Temperature gradient	20 °C/hour maximum

Air cooling requirement

The host system must provide sufficient air flow across the drive to maintain the temperature at less than 60°C at the center of the top cover of the drive.

Operating shock

The drive is designed to withstand with no hard error a 150 G half-sine wave shock pulse of 2 ms duration or 10 G for 11 ms.

Non-operating shock

The drive is designed to withstand with no permanent damage or degradation in performance a 120 G half-sine wave shock pulse of 11 ms duration or 1000 G for 1 ms.

Operating and non-operating vibration

Due to the complexity of this subject we recommend that users contact the distributor to discuss how to perform the necessary measurements if they believe this to be an area which requires evaluation.

Electromagnetic compatibility

The drive meets the following worldwide EMC requirements when installed in a suitable enclosure and exercised with a random accessing routine at the maximum data rate:

United States Federal Communications Commission (FCC) Rules and Regulations (Class B), Part 15.

This drive is certified for compliance to EC directive 89/336/EEC.

C-Tick Mark complies with Australian EMC standard, AS/NZS 3548 : 1995 Class B.

Drive usage conditions

The drive is designed to be used under the following conditions:

- Levels of shock, vibration, temperature, humidity, altitude, and magnetic field are within the specifications.
- Precautions are taken to prevent electrostatic discharge (ESD).
- The breathing hole on top of the drive is not covered.
- Pressure is not applied to the top cover of the drive.

- The drive is operated within the specification of less than 140 power-on hours per month.
- The Seeing, Writing, and Reading operations of the drive constitute no more than 20% of power-on hours.
- The power requirements of the drive are satisfied.
- The interface connector is firmly mated.
- The proper power off sequence is followed (see the drive specification for further details).

Mechanical data

Dimensions	S.I. Metric (mm)
Height	5.0 +0.0/-0.1
Width	42.80 ± 0.101
Length	36.40 ± 0.15

Weight 16 grams maximum

The drive will mount in all axes (six directions).

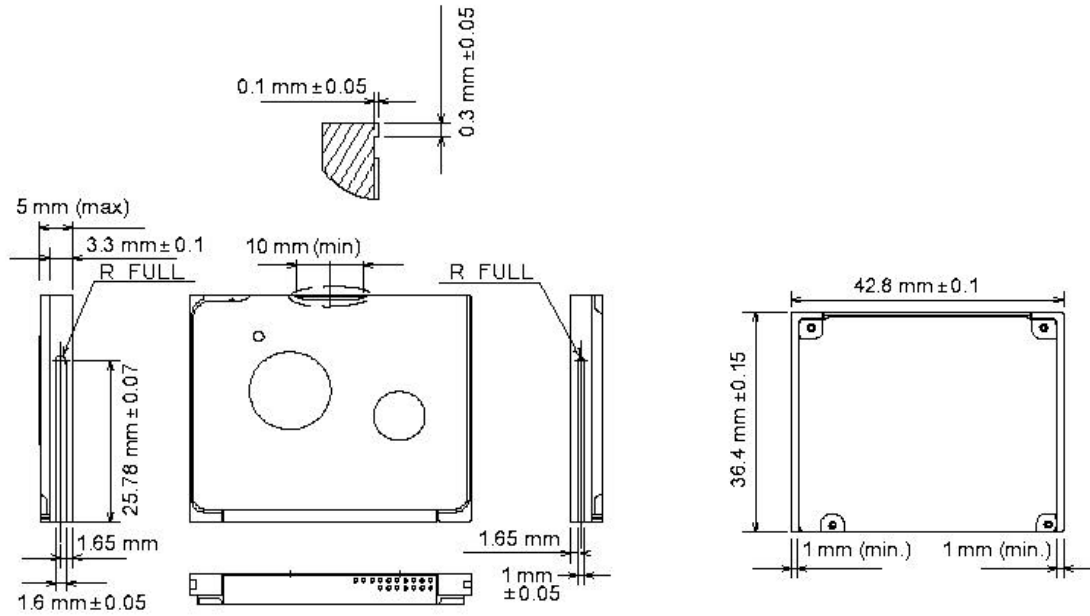



© International Business Machines Corporation 2000

www.ibm.com/harddrive

IBM Technology Group Support Center

Telephone: 888.IBM.5214 or 507.286.5825

E-mail: drive@us.ibm.com

Singapore Technology Group Support Center

Telephone: (65)6418.9595 or 1800.418.9595

E-mail: drive@sg.ibm.com

UK Technology Group Support Center

Telephone: 44.1475.898.125

E-mail: drive@uk.ibm.com

Germany Technology Group Support Center

Telephone: 49.7032.153050

E-mail: drive@de.ibm.com

IBM Systems Storage Division

5600 Cottle Road

San Jose CA 95193

www.ibm.com/storage

Printed in the United States of America

05-2000

All Rights Reserved

IBM is the registered trademark of International Business Machines Corporation.

Other company, product, and service names may be trademarks or service marks of others.

Produced by the IBM Technology Group Support Center.

OEM Hark Disk Drive Specifications for
DMDM-10340/10170, IBM microdrive with CF+ Type II
Interface, revision 1.01

Product Description data represents IBM's design objectives and is provided for comparative purposes; actual results may vary based on a variety of factors. This product data does not constitute a warranty. Questions regarding IBM's warranty terms or methodology used to derive this data should be referred to the IBM Technology Group Support Center.

Data subject to change without notice.

Date: 23 May, 2000