

Hitachi Global Storage Technologies

Product summary

Hitachi Travelstar 60GH & 40GN

2.5 inch ATA/IDE hard disk drive

Enhanced Availability model

Models: IC25T060ATCX05
IC25N040ATCX04
IC25N030ATCX04
IC25N020ATCX04
IC25N010ATCX04



Features

Benefits

<ul style="list-style-type: none">▪ Capacities: 10, 20, 30, 40 & 60 GB at 512 bytes/sector▪ Height: 12.5 mm (60-GB model) 9.5 mm (all other models)	<ul style="list-style-type: none">▪ High capacity in a slim 2.5 inch form factor
<ul style="list-style-type: none">▪ Interface transfer rates: up to 100 MB/s	<ul style="list-style-type: none">▪ Popular interface with excellent performance
<ul style="list-style-type: none">▪ Nonoperational shock: 700 G/1 ms (60-GB model) 800 G/1 ms (all other models)▪ Operational shock: 150 G/2 ms (60-GB model) 200 G/2 ms (all other models)	<ul style="list-style-type: none">▪ Robust design for portable computing applications
<ul style="list-style-type: none">▪ Media data transfer rate: 146 - 262 Mb/s (60-GB model) 125 - 245 Mb/s (all other)▪ Rotational speed: 5400 RPM (60-GB model) 4200 RPM (all other models)	<ul style="list-style-type: none">▪ Excellent data rate across disk surface
<ul style="list-style-type: none">▪ Average seek time: 12 ms (read)▪ Average latency: 5.5 ms (60-GB model) 7.1 ms (all other)	<ul style="list-style-type: none">▪ Fast access to data
<ul style="list-style-type: none">▪ Segmented buffer with 2 MB write cache (upper 280 KB used for firmware)▪ Enhanced ECC On-The-Fly▪ Giant Magnetoresistive heads	<ul style="list-style-type: none">▪ Fast access to data and improved throughput▪ High reliability▪ High areal density, low component count
<ul style="list-style-type: none">▪ No-ID sector formatting▪ PRML data channel▪ Multizone recording	<ul style="list-style-type: none">▪ More data stored per track, increased sustained data transfer rate
<ul style="list-style-type: none">▪ Fluid Dynamic Bearing motor technology	<ul style="list-style-type: none">▪ Quiet drive operation
<ul style="list-style-type: none">▪ Load/Unload heads	<ul style="list-style-type: none">▪ Increased durability during power save modes and non-operation
<ul style="list-style-type: none">▪ S.M.A.R.T. function▪ Drive Fitness Test (DFT) technology	<ul style="list-style-type: none">▪ Protection of user data
<ul style="list-style-type: none">▪ Glass substrate disks	<ul style="list-style-type: none">▪ Improved data integrity▪ Longer disk lifetime

Electrical connector locations

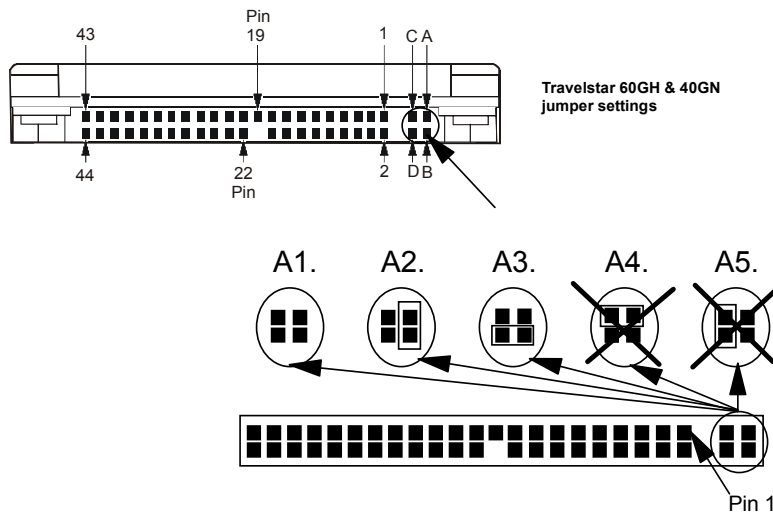

Drive Address

The position of jumpers on the interface connector determines the address of the drive. In the illustration the jumper pins on the interface connector are labeled A, B, C, and D.

- ◆ A master drive requires no jumper.
- ◆ A slave drive requires a jumper on pins A & B (A2).
- ◆ Cable Select requires a jumper on pins D & B (A3).
- ◆ All other settings are reserved.

Cabling

Maximum cable length from host system to the drive is 18 inches.

AT Signal Connector

The signal connector for AT attachment mates with the 50-pin plug specified in the ATA/ ATAPI-5 T13/1321D speci-

fication, Rev. 3.

DC power requirements

Nominal supply	+5 Volt dc	Supply rise time	7–100 ms
Power supply ripple (0-20 MHz)	100 mV p-p max. ¹	Supply voltage	–0.3 to + 6.0 V
Tolerance	±5% ²		

Watts RMS typical	10, 20 GB Models	30, 40 GB Models	60 GB Model
Performance Idle average ³	1.85	1.8	2
Read average ⁴	2.0	2.1	2.5
Write average	2.1	2.2	2.7
Seek average ⁵	2.3	2.3	2.6
Standby	0.25	0.25	0.25
Sleep	0.1	0.1	0.1
Startup (maximum peak) ⁶	4.7	4.7	5.0
Average from power on to ready	3.3	3.3	3.8

Notes:

1. The maximum fixed disk ripple is measured at the 5 V dc input of the drive
2. The drive does not incur damage for an over voltage condition of +25% (max. duration of 20 ms) on the 5-Volt nominal supply
3. The idle current is specified at an inner track
4. The read/write current is specified based on three operations of 63 sector read/write per 100 ms
5. The seek average current is specified based on three operations per 100 ms
6. The worst case operating current includes motor surge

Data organization

Capacity	60 GB model	40 GB model	30 GB model	20 GB model	10 GB model
Number of heads	8	4	3	2	2
Sectors/track	307-556		336-672		
Number of cylinders			16,383		
Total cust. usable data sectors	117,210,240	78,140,160	58,605,120	39,070,080	19,640,880
Total cust. usable data bytes	60,011,642,880	40,007,761,920	30,005,821,440	20,003,880,960	10,056,130,560

Command descriptions

The following commands are supported by the drive:

Commands	(Hex)	P	Commands	(Hex)	P	Commands	(Hex)	P
Check Power Mode	E5	3	Read Native Max ADDRESS	F8	3	S.M.A.R.T. Enable/Disable Attribute Autosave	B0	3
Check Power Mode*	98	3	Read Sectors	20	1	S.M.A.R.T. Enable/Disable Automatic Off-line	B0	3
Device Configuration Restore	B1	3	Read Sectors	21	1	S.M.A.R.T. Enable Operations	B0	3
Device Configuration Freeze Lock	B1	3	Read Verify Sectors	40	3	S.M.A.R.T. Execute Off-line Immediate	B0	3
Device Configuration Identify	B1	1	Read Verify Sectors	41	3	S.M.A.R.T. Read Attribute Values	B0	1
Device Configuration Set	B1	2	Recalibrate	1x	3	S.M.A.R.T. Read Attribute Thresholds	B0	1
Enable/Disable Delayed Write	FA	3	Security Disable Password	F6	2	S.M.A.R.T. Read Log Sector	B0	1
Execute Device Diagnostic	90	3	Security Erase Prepare	F3	3	S.M.A.R.T. Return Status	B0	3
Flush Cache	E7	3	Security Erase Unit	F4	2	S.M.A.R.T. Save Attribute Values	B0	3
Format Track	50	2	Security Freeze Lock	F5	3	S.M.A.R.T. Write Log Sector	B0	2
Format Unit	F7	3	Security Set Password	F1	2	Standby	E2	3
Identify Device	EC	1	Security Unlock	F2	2	Standby*	96	3
Idle	E3	3	Seek	7x	3	Standby Immediate	E0	3
Idle*	97	3	Sense Condition	F0	3	Standby Immediate*	94	3
Idle Immediate	E1	3	Set Features	EF	3	Write Buffer	E8	2
Idle Immediate*	95	3	Set Max ADDRESS	F9	3	Write DMA	CA	4
Initialize Device Parameters	91	3	Set Max FREEZE LOCK	F9	3	Write DMA	CB	4
Read Buffer	E4	1	Set Max LOCK	F9	3	Write Long	32	2
Read DMA	C8	4	Set Max SET PASSWORD	F9	2	Write Long	33	2
Read DMA	C9	4	Set Max UNLOCK	F9	2	Write Multiple	C5	2
NOP	0	3	Set Multiple Mode	C6	3	Write Sectors	30	2
Read Long	022	1	Sleep	E6	3	Write Sectors	31	2
Read Long	23	1	Sleep*	99	3	Write Verify	3C	2
Read Multiple	C4	1	S.M.A.R.T. Disable Operations	B0	3			

Protocol

- 1 : PIO data IN command
- 2 : PIO data OUT command
- 3 : Non data command
- 4 : DMA command

Note: Commands marked * are alternate command codes for previously defined commands.



ATTENTION: The drive must be protected against electrostatic discharge especially when being handled. The safest way to avoid damage is to put the drive in an anti-static bag before ESD wrist straps are removed.

Drives should only be shipped in approved containers. Severe damage can be caused to the drive if the packaging does not adequately protect against the shock levels induced when a box is dropped. Consult your Hitachi Global Storage Technologies representative if you do not have an approved shipping container.

Signal definitions

PIN	SIGNAL	I/O
01	-RESET	I
02	GND	
03	DD07	I/O
04	DD08	I/O
05	DD06	I/O
06	DD09	I/O
07	DD05	I/O
08	DD10	I/O
09	DD04	I/O
10	DD11	I/O
11	DD03	I/O
12	DD12	I/O
13	DD02	I/O
14	DD13	I/O
15	DD01	I/O
16	DD14	I/O
17	DD00	I/O
18	DD15	I/O
19	GND	
(20)	Key	
21	DMARQ	O
22	GND	
23	-DIOW(*)	I
24	GND	
25	-DIOR(*)	I
26	GND	
27	IORDY(*)	O
28	CSEL	I
29	-DMACK	I
30	GND	
31	INTRQ	O
32	-IOCS16(*)	O
33	DA01	I
34	-PDIAG	I/O
35	DA00	I
36	DA02	I
37	-CS0	I
38	-CS1	I
39	-DASP	I/O
40	GND	
41	+5V logic	power
42	+5V motor	power
43	GND	
44	(reserved)	

Notes

1. "O" - an output from the drive.
2. "I" - an input to the drive.
3. "I/O" - an input/output common.
4. "OD" - an Open-Drain output.

5. The signal lines marked with (*) are redefined during the Ultra DMA protocol to provide special functions. These lines change from the conventional to special definitions at the moment the host decides to allow a DMA burst, if the Ultra DMA transfer mode was previously chosen via SetFeatures. The drive becomes aware of this change upon assertion of the -DMACK line. These lines revert back to their original definitions upon the deassertion of DMACK at the termination of the DMA burst.
6. "Power" - a power supply to the drive.
7. "Reserved" - reserved pins which must be left unconnected.

	Special definition (for Ultra DMA)	Conventional definition
Write operation	-DDMARDY	IORDY
	HSTROBE	-DIOR
	STOP	-DIOW
Read operation	-HDMARDY	-DIOR
	DSTROBE	IORDY
	STOP	-DIOW

5 V power

There are two input pins for the +5 V power supply: the "+5 V Logic" pin and the "+5 V dc Motor" pin. These two input pins are tied together within the drive.

Operating environment

The drive operates within its performance limits when the following environment is maintained. Product life calculations are based on the nominal environment for a typical application.

Relative humidity (noncondensing)	
Operating	8 to 90%
Nonoperating	5 to 95%

Wet bulb temperature (noncondensing)	
Operating	29.4°C
Nonoperating	40°C

Altitude	
Operating	-300 to 3,048 m (10,000 ft)
Nonoperating	-300 to 12,192 m (40,000 ft)

Temperature

Operating	5 to 40°C
Nonoperating	-40 to 65°C
Max. gradient	20°C/hour

Note: The system is responsible for providing sufficient air movement to maintain surface temperatures below 50°C at the center of top cover and below 53°C at the center of the drive circuit board assembly.

Operating shock

The drive withstands the following half sine wave shock pulse with no data loss or permanent damage.

Model	Duration	
	2 ms (G)	11 ms (G)
60 GB	150	15
All other	200	15

The shock test consists of ten shock inputs in each axis and direction for a total of 60; there is a minimum 3 seconds delay between shock pulses. Soft errors and automatic retries are allowed during the test.

The input level is applied to the normal disk drive subsystem mounting points used to secure the drive in a normal system.

Nonoperating shock

The drive withstands the following half sine wave shock pulse with no data loss or permanent damage.

Model	Duration	
	2 ms (G)	11 ms (G)
60 GB	700	120
All other	800	120

All shocks are applied in each direction of the three mutually perpendicular drive axes, one axis at a time. Input levels shall be measured at the base plate where the drive is attached with four screws.

Operating vibration

Random vibration.

The drive withstands the following vibration levels without a hard error. The test consists of 30 minutes of random vibration using the power spectral density (PSD) levels specified in the following table, applied in each of the three mutually perpendicular axes at the normal drive mounting points.

Hz	PSD (G ² /Hz)
5	2.0 x E-5
17	1.1 x E-3
45	1.1 x E-3
48	8.0 x E-3
62	8.0 x E-3
65	1.0 x E-3
150	1.0 x E-3
200	5.0 x E-4
500	5.0 x E-4

Note: Overall RMS level of vibration is 0.67G.

Swept Sine Vibration Limits

The drive will operate without a hard error while being subjected to the following swept sine vibration level (applied and measured at the normal drive mounting points): 1G zero-to-peak from 5 to 500 Hz with a sweep rate of 2.0 Octaves/minute

Nonoperating vibration

Random vibration

The drive withstands the following vibration levels without loss or permanent damage. The test consists of 30 minutes of random vibration applied in each of the three mutually perpendicular axes at the normal drive mounting points. The PSD levels for this test simulating the shipping and relocation environment are shown below.

Hz	G ² /Hz
2.5	0.001
5	0.03
40	0.18
500	0.18

Note: Overall RMS level of vibration is 3.01G.

Swept Sine Vibration Limits

No permanent damage will occur when the drive is subjected to the following swept sine vibration level (applied and measured at the normal drive mounting points) with no power applied to the drive (heads in the unload position): 5G zero-to-peak from 10 to 500 Hz with a sweep rate of 0.5 Octaves/minute, 25.4 mm double amplitude displacement from 5 to 10 Hz.

Electromagnetic compatibility

The drive, when installed in a suitable enclosure and exercised with a random accessing routine at maximum data rate, shall meet the following worldwide electromagnetic compatibility (EMC) requirements:

- United States FCC (Federal Communications Commission) Rules and Regulations (Class B),
- Part 15.RFI Suppression German National Requirements.
- RFI Japan VCCI Requirements.
- EU EMC Directive Technical Requirements and Conformity Assessment Procedures.

Acoustics

The criteria of A-weighted sound power level are described below.

Measurements are to be taken in accordance with ISO 7779. The mean of the sample of 40 drives is to be less than the typical value. Each drive is to be less than the maximum value. The drives are to meet this requirement in both board down orientations.

A-weighted Sound Power	Typical (Bel)	Max (Bel)
60 GB Model		
Idle	2.5	2.7
Operating	3.5	3.8
40, 30 GB Models		
Idle	2.4	2.6
Operating	3.1	3.3
20, 10 GB Models		
Idle	2.1	2.4
Operating	2.7	2.9

The background power levels of the acoustic test chamber for each octave band are to be recorded.

Sound power tests are to be conducted with the drive supported by spacers so that the lower surface of the drive is located 25±3 mm above the chamber floor. No sound absorbing material shall be used.

S.M.A.R.T. function

The intent of Self-Monitoring, Analysis, and Reporting Technology (S.M.A.R.T.) is to protect user data and prevent unscheduled system downtime that may be caused by predictable degradation or fault of the device. By monitoring and storing critical performance and calibration parameters, S.M.A.R.T. devices employ sophisticated data analysis algorithms to predict the likelihood of near-term degradation or a fault condition. By alerting the host system of a negative reliability status condition, the host system can warn the user of the impending risk of a data loss and advise the user of appropriate action.

Since S.M.A.R.T. utilizes the internal device microprocessor and other device resources, there may be some small overhead associated with its operation. However, special care has been taken in the design of the S.M.A.R.T. algorithms to minimize the impact to performance of the host system. Actual impact of S.M.A.R.T. overhead is dependent on the specific device design and the usage patterns of the host system. For further information refer to the hard disk drive specification for the Travelstar 60GH & 40GN Hard Disk Drive Specifications, Enhanced Availability Model.

Load/Unload heads

The heads are unloaded by putting into operation one of the following commands:

```
HARD RESET
STANDBY
STANDBY IMMEDIATE
SLEEP
```

When the heads are unloaded, they rest in a small detent. To prevent the heads from being thrown off the ramp during angular acceleration, a bidirectional, normally open, mechanical latch engages with the actuator to keep it from turning in the head loading direction. This action causes a "rattle" sound which can be mistaken for loose parts

Drive usage condition

The expected product life is five years under typical mobile system conditions. The drive is designed to be used under the following conditions:

- 732 power on hours per month.
- Seeking, writing, and reading operation is 50% of power on hours at 40° C or lower.
- The drive is operated within specifications of shock, vibration, temperature, humidity, altitude, and magnetic field.
- The drive is protected from ESD.
- The breathing hole on top of the drive is not covered.
- Force is not applied to the cover of the drive.
- The specified power requirements of the drive are satisfied.
- The drive frame is grounded electrically to the system by four screws.
- The drive is mounted with the recommended screw depth and torque.
- The physical and electrical requirements of the interface satisfy ATA-5.
- The proper power-off sequence is used.

For further information refer to the Travelstar 60GH & 40GN Hard Disk Drive Specifications, Enhanced Availability Model.

Mechanical data

Weight (grams - max)

60 GB model	155
40, 30 GB models	99
20, 10 GB models	95

Dimensions (mm)

Height:	60 GB model	12.5±0.2
	All other models	9.5±0.2
Width		69.85±0.25
Length		100.2±0.25

Mounting orientation

The recommended mounting screw torque is 3.0 ± 0.5 kgf-cm.

The recommended mounting screw depth is 3.0 ± 0.3 mm for bottom mounting and 3.5 ± 0.5 mm for horizontal mounting.

The drive mounting hole locations and sizes are shown in the illustrations below.

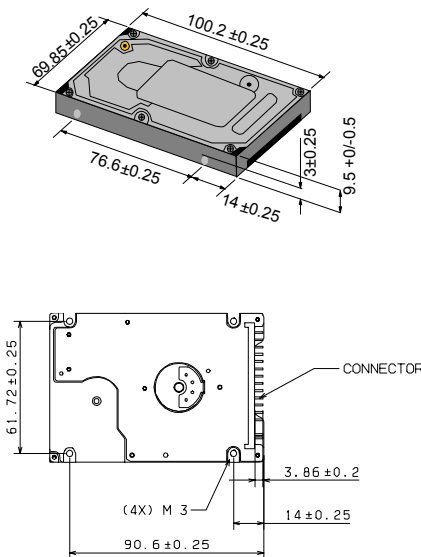

© Copyright Hitachi Global Storage Technologies

Hitachi Global Storage Technologies
5600 Cottle Road
San Jose, CA 95193

Produced in the United States

1/03

All rights reserved Deskstar™ is a trademark of Hitachi Global Storage Technologies.

Microsoft, Windows XP, and Windows are trademarks of Microsoft Corporation in the United States, other countries, or both.

Other product names are trademarks or registered trademarks of their respective companies.

References in this publication to Hitachi Global Storage Technologies products, programs or services do not imply that Hitachi Global Storage Technologies intends to make these available in all countries in which Hitachi Global Storage Technologies operates.

Product information is provided for information purposes only and does not constitute a warranty.

Information is true as of the date of publication and is subject to change. Actual results may vary.

This publication is for general guidance only. Photographs may show design models.

13 January 2003