

H2172-A2, H2258-A3 & H2344-A4

These 2.5" disk drives from IBM provide up to 344 MB in a slim 17 mm high package. Using the latest MR head technology IBM provides high performance drives particularly suited to the mobile computing market.

APPLICATIONS

- High performance portable computers
- Non-IT--process control/fax
- Removable/secure storage units

FEATURES

- 172/258/344 MB at (512 bytes/sector)
- IDE interface with 6 MB/s cap transfer rate
- Media data rate 20.0/32.0 Mbits/s (8 zones)
- Rotational speed 3800 rpm
- Magneto resistive heads
- 32 KB Read Buffer
32 KB Write Cache
ECC on the fly
- 0.4 watts stand by
- Shock 250 G (2 ms) non op
All 6 axis mounting
- Spin up 3 sec (typical)

BENEFITS

- High capacity 2.5" drives
- Popular interface with excellent performance
- Excellent data rate across disk surface
- High areal density, low component count
- Fast access to data and improved throughput
- Low power for battery powered applications
- Robust design for portable computing applications

ELECTRICAL CONNECTOR LOCATIONS

Drive address

The jumper cable is available at the interface connector to determine the drive address. Using Cable Selection, the drive address depends on the condition of pin 28 for the AT interface cable. In the case when pin 28 is ground or low, the drive is a Master. If pin 28 is open or high level, the drive is a Slave.

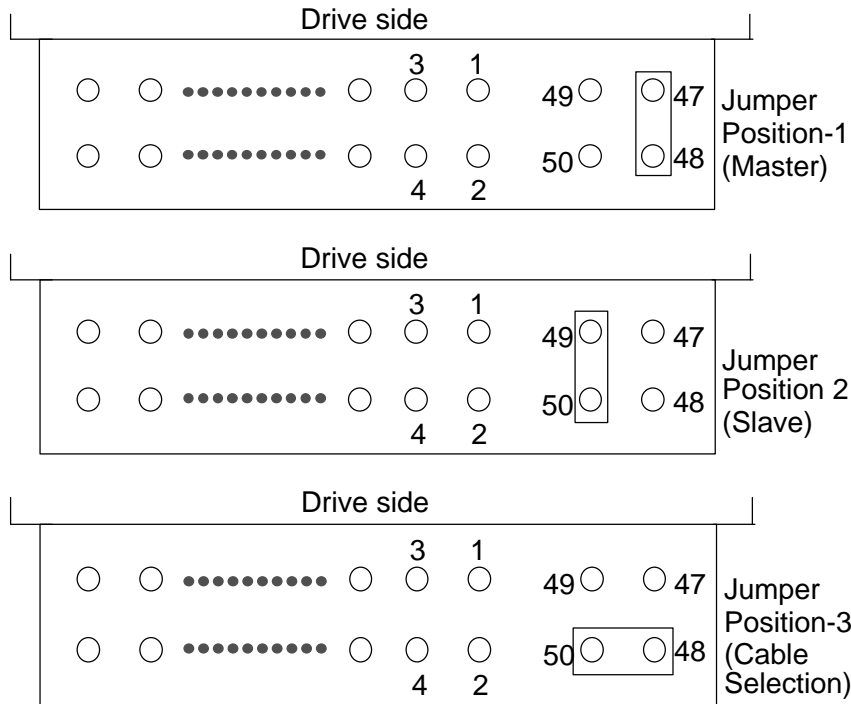

Drive address by jumper cable

Cabling

The maximum cable length from the host system to the HDD plus circuit pattern length in the host system shall not exceed 18 inches.

AT signal connection

The AT signal connector is designed to mate with Dupont PN 69764-044 or equivalent.

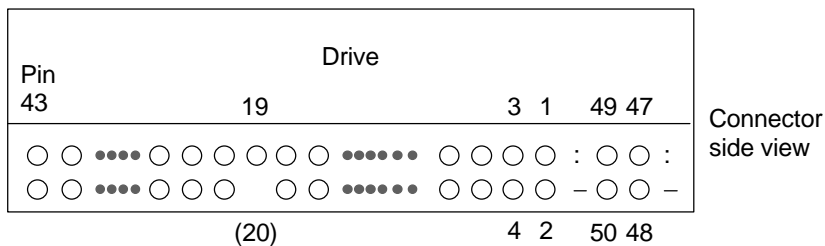

44 Pin AT connector

Notes:

1. Pin position 20 is left blank for secure connector insertion.
2. Pin position 47 through 50 are used for drive address setting.

DATA ORGANIZATION

Physical layout	H2172-A2	H2258-A3	H2344-A4
Bytes per Block	512	512	512
Total Customer Usable Data Bytes (MB)	172	258	344

Logical layout

	989	989	915
	10	15	15
	34	34	49
	172	258	344

DC POWER REQUIREMENTS

Supply Voltage	+5 Volts		
Power Supply Ripple (0-20 MHz) (1)	100 mv p-p max		
Tolerance (2)	+/- 5%	Supply Current	Pop Mean
Idle average (3)	0.27 A RMS		
Read/Write	0.56 A RMS		
Seek average (4)	0.40 A RMS		
Standby	0.08 A RMS		
Start up	0.94 A RMS (maximum peak) (5)		
Supply Rise Time	7-100 ms		

Notes:

1. The maximum supply ripple is measured at 5 volt input of the HDD.
2. The disk drive shall not incur damage for an over voltage condition of +25% (maximum duration of 20 ms) on the 5 volt nominal supply.
3. Idle average current includes communication currents.
4. The seek average current is specified based on one operation per second.
5. The worst case operating current includes motor surge.

SIGNAL DEFINITION

The pin assignments of interface signals are listed as follows:

PIN	Signal	I/O	PIN	Signal	I/O
01	-HRESET	I	02	GND	
03	HD07	I/O	04	HD08	I/O
05	HD06	I/O	06	HD09	I/O

07 HD05	I/O	08 HD10	I/O
09 HD04	I/O	10 HD11	I/O
11 HD03	I/O	12 HD12	I/O
13 HD02	I/O	14 HD13	I/O
15 HD01	I/O	16 HD14	I/O
17 HD00	I/O	18 HD15	I/O
19 GND		(20) Key	
21 (Resv)		22 GND	
23 -HIOW	I	24 GND	
25 -HIOR	I	26 GND	
27 IRODY	O	28 CSEL	I
29 (Resv)		30 GND	
31 HIRQ	O	32 -HIOCS16	O
33 HA01	I	34 -PDIAG	I/O
35 HA00	I	36 HA02	I
37 -HCSO	I	38 -HCSI	I
39 -DASP	I/O	40 GND	
41 +5V Logic	PWR	42 +5V Motor	PWR
43 GND	I	44 (Resv)	

Note:

"O" designates an output from the Drive.

"I" designates an input to the Drive.

"I/O" designates an input/output common.

"PWP" designates a power supply to the Drive.

"(Resv)" designates reserved pins which must be left unconnected.

Note: There are two input pins for +5 V power supply, "+5 V LOGIC" and "+5 V MOTOR".

"+5 V LOGIC" is connected to the internal logic circuits and "+5 V MOTOR" is connected to the spindle motor and motor driver.

It is possible to turn on and off "+5 V LOGIC" by an external switch circuit to reduce power consumption to the least possible. In this mode, a voltage drop out due to the motor spin up current can be reduced by connecting "+5 V MOTOR" line into the system power source directly.

If the above power management option is used, all signal lines that will electrically active in the host system while the HDD is disconnected from power line shall be isolated by Three-State line drivers. Internal leakage through ESD protection circuit may pull down LPUL (Least Positive Up Level) of logic signal below the specification.

Use both lines in parallel, for regular HDD application.

COMMAND DESCRIPTION

The following Commands are supported by the Drive:

COMMANDS	(Hex)
Check Power Mode	(E5)
Check Power Mode	(98)
Disable Lock	(F6)

Execute Drive Diagnostics	(90)
Erase Prepare	(F3)
Erase Unit	(F4)
Format Track	(50)
Freeze Lock	(F5)
Identify Drive	(EC)
Idle	(E3)
Idle	(97)
Idle Immediate	(E1)
Idle Immediate	(95)
Initialize Drive Parameters	(91)
Read Buffer	(E4)
Read Long (retry)	(22)
Read Long (no retry)	(23)
Read Multiple	(C4)
Read Sectors (retry)	(20)
Read Sectors (no retry)	(21)
Read Verify Sectors (retry)	(40)
Read Verify Sectors (no retry)	(41)
Recalibrate	(1X)
Seek	(7X)
Set Features	(EF)
Set Multiple	(C6)
Set Password	(F1)
Sleep	(E6)
Sleep	(99)
Standby	(E2)
Standby	(96)
Standby Immediate	(E0)
Standby Immediate	(94)
Unlock	(F2)
Write Buffer	(E8)
Write Long (retry)	(32)
Write Long (no retry)	(33)
Write Multiple	(C5)
Write Sectors (retry)	(30)
Write Sectors (no retry)	(31)
Write Verify	(3C)

OPERATING MODES

Description

Spin-Up

Start up time period from spindle stop or power down.

Seek

Seek operation mode.

Write

Write operation mode.

Read

Read operation mode.

Idle

Spindle motor and Servo system are working normally. Other modules except the servo control and Host Interface are sleeping. Commands can be received and processed immediately.

Standby

Spindle motor is stopped. All modules except Interface are sleeping. Commands can be received immediately. HDD is an interrupt waiting mode with the lowest power dissipation.

Notes:

1. Upon power down or Spindle stopped, a head locking mechanism will secure the heads in the ID parking position.
2. Sleep command is handled like the Standby command. Recovering from standby mode does not need soft reset nor hard reset.

ELECTROMAGNETIC COMPATIBILITY

The Drive meets the following EMC requirements when installed in the user system and exercised with a random accessing routine at maximum data rate:

United States Federal Communication Commission (FCC) Rules and Regulation Part 15: Subject J-Computer Devices "Class B Limits."

European Economic Community (EEC) directive #76/889 related to the control of radio frequency interference and the Verband Deutscher Elektrontechniker (VDE) requirements of Germany (GOP).

OPERATING ENVIRONMENT

Humidity:

Operating Relative 8% to 90% non-condensing

Non-Operating Relative 5% to 95% non-condensing

Wet bulb temperature:

Maximum Wet Bulb:

Operating 29.4 degrees C non-condensing

Non-Operating 40.0 degrees C non-condensing

Elevation:

Operating Altitude -50 to 3000 m
Ship/Storage Altitude -150 to 30000 m

Temperature:

Operating 5 to 55 degrees C
Storage 0 to 65 degrees C
Shipping -40 to 65 degrees C
Temperature Gradient 20 degrees per hour (maximum)
(Operating, Storage & Shipping)

Note: The system is responsible for providing sufficient air movement to maintain surface temperature below 60 degrees C at the center of top cover of the drive.

AIR COOLING REQUIREMENT:The host system must provide sufficient air flow across the drive to maintain the temperature at less than 60 degrees C (measured at the center of the drives' top cover).

OPERATING SHOCKThe Drive will withstand (with no hard error) a 10 G half-sine wave shock pulse of 11 ms duration.

NON-OPERATING SHOCKThe Drive will withstand (with no permanent damage or degradation in performance) a 120 G half-sine wave shock pulse of 11 ms duration or 250 G for 2 ms.

OPERATING AND NON-OPERATING VIBRATIONDue to the complexity of this subject we recommend that users contact the Distributor to discuss how to perform the necessary measurements, if they believe this to be an area which requires evaluation.

MECHANICAL DATA

<i>DIMENSIONS</i>	<i>H2172-A2</i>	<i>H2258-A3</i>	<i>H2344-A4</i>
Height (mm)	17.0 + 0.35/-0.3	17.0 + 0.35/-0.3	17.0 + 0.35/-0.3
Width (mm)	70.0 +/- 0.25	70.0 +/- 0.25	70.0 +/- 0.25
Length (mm)	100.0 +/- 0.25	100.0 +/- 0.25	100.0 +/- 0.25
Weight (gram)	173 Max	180 Max	180 Max

MOUNTING ORIENTATIONThe drive will operate in all axes (6 directions). The drive will operate within the specified error rates when tilted +/- 5 degrees from these positions. Performance and error rate will stay within specification limits if the drive is operated in the other permissible orientations from which it was formatted Thus a drive formatted in a horizontal orientation will be able to run vertically and vice versa.

The recommended mounting screw torque is 3 +/- 0.5 kgf cm.

The recommended mounting screw depth is 3.5 +/- 0.5 mm for bottom and 5.0 +/- mm for horizontal mounting.

The system is responsible for mounting the drive securely enough to prevent excessive motion or vibration of the drive at seek operation or spindle rotation, using appropriate screws or equivalent mounting hardware. Consult the issuer of this specification for actual application.

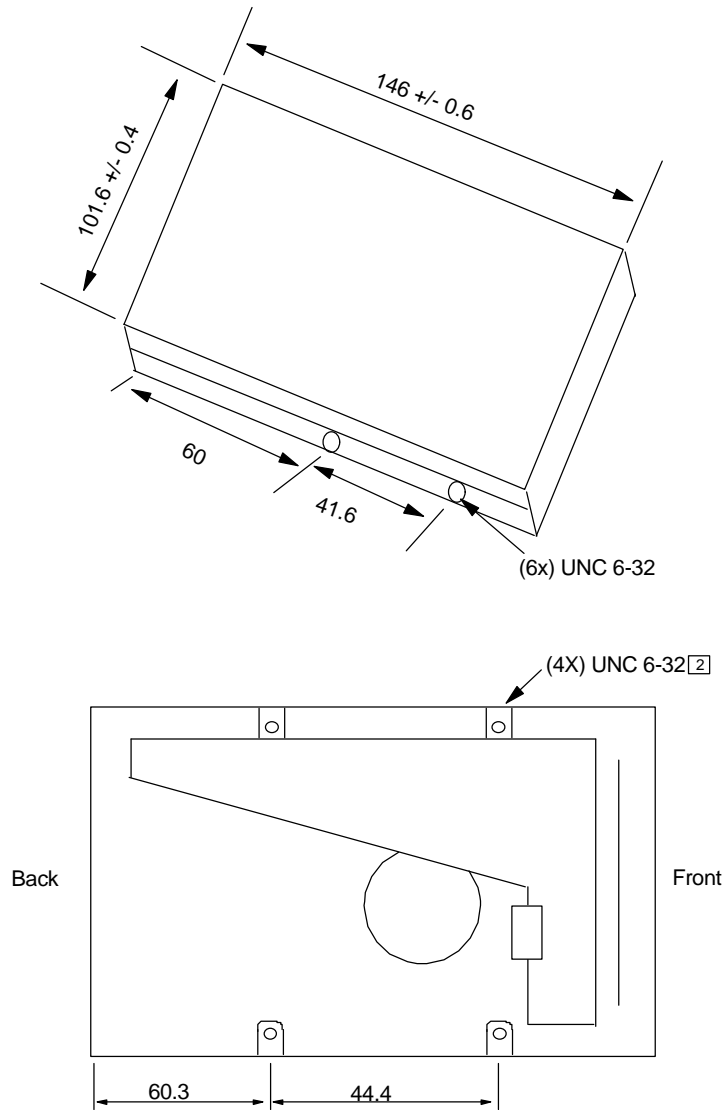

Vibration test and shock test are to be conducted with mounting the drive to the table using bottom four screws.

The maximum allowable penetration of the mounting screw is 3.5 mm.

PACKAGING:

The drive must be protected against Electro-Static Discharge especially when being handled. The safest way to avoid damage is to put the drive in an anti static bag before ESD wrist straps, etc are removed.

Drives should only be shipped in approved containers, severe damage can be caused to the drive if the packaging does not adequately protect against the shock levels induced when a box is dropped. Consult your IBM marketing representative if you do not have an approved shipping container.

AMP is a trademark of AMP Incorporated.

Molex is a trademark of Molex Incorporated.

DATA MATE is a trade mark of AMP Incorporated.

Western Digital is a trademark of the Western Digital Corporation.

NEXT is a trademark of NEXT Corporation.

This data sheet is not a substitute for the full product specification, which should be used when detailed information is required.

Product Description data represents IBM's design objectives and is provided for comparative purposes; actual results may vary based on a variety of factors. This product data does not constitute a warranty. Questions regarding IBM's warranty terms or methodology used to derive this data should be referred to your IBM OEM representative. Data subject to change without notice.